

INSTRUCTION MANUAL Worktop lift Baselift

6200



6201



6202



6203





**For more information, see:
www.granberg.se**

Contents

Section:	Headline:	Page:
1.	Introduction	4
2.	Declaration of Conformity	4
3.	Intended use - Technical data.....	4
	Installation instructions:	
4.1	Mechanical construction	5
4.2	Delivery modules.....	6
4.3	Joist heights, location of wall socket, water and sewerage	7
4.4	Electric connections	8
4.5	Water and sewerage connections.....	8
4.6	Installation of straight worktop lift, series 6200.....	9
4.7	Installation of L-shaped worktop lift, series 6201, 6202	13
4.8	Installation of L-shaped worktop lift, series 6203	17
4.9	Mounting of fronts.....	20
4.10	Mounting of push button.....	20
4.11	Mounting of Alu rear edge trim	21
4.12	Mounting of top board.....	21
4.13	Mounting of complete sink unit	22
4.14	Mounting of cover plates	23
4.15	Mounting of end covers for cover plates.....	25
4.16	Functional test.....	25
4.17	Adjust the inclination of the worktop lift	25
	Operator's information:	
5.1	Safe use.....	26
5.2	Safety arrangements.....	26
5.3	Load distribution and side forces.....	27
5.4	Actions after use.....	27
5.5	Alternative control devices	27
5.6	Cleaning.....	28
5.7	Maintenance	28
6.	Instructions for Recycling.....	28
7.	Decals	28
8.	Warranty	29
9.	Service & maintenance records.....	29
10.	Fault finding	30
11.	Spare parts list.....	30
12.	Electric system / Electric circuit diagram	31
13.	CE-Declaration of conformity	31

1. Introduction

We have the pleasure to deliver a Granberg Interior Baselift, an electrically operated lifting and lowering system. The Worktop lift unit can be used separately, or together with the Granberg Wall cabinet lifts, and it becomes then a total adaptation of the kitchen. The lift is suitable for kitchens of various makes, which are made according the standards EN 1116 and EN 1153.

Only authorized persons may use the Worktop lift unit!

Authorization means obligation to read and follow the instructions.

It is very important that you read and understands the instructions before you use the device.

If you have any questions - contact your supplier.

This Instruction manual shall be available for all concerned persons, be kept in a protected place and shall follow the product, if it is moved to another installation site or another house or apartment owner.

Correct use, operation, inspections and maintenance are decisive for efficient and safe work.

2. Declaration of conformity with EU directives

This product is CE-marked and is thereby declared to conform to the basic functionality and safety requirements of current Machinery, EMC and Low Voltage Directives.

A separate "EC Declaration of Conformity" will be found in Section 13.

3. Intended use - Technical data

The Baselift is intended to vertically lift and lower the worktop to achieve a convenient location performing normal kitchen work. The operation shall be indoors, under normal housing conditions regarding temperature, humidity and lighting. In the worktop cassette e.g. electric hob and a sink can be incorporated.

The worktop lift unit is not intended for use in moist environments.

It is assumed that the work top benches and the cabinets are made according the standards EN 1116 and EN 1153.



Countertop on adjacent cabinets must not protrude over its cabinet frame. Protrusion of the countertop to adjacent cabinets constitute a risk of crushing and will not be accepted!

Any use other than the above is subject to approval by Granberg and definition of the current allowable working conditions. Contact Granberg to planned change approved!

* Solid wood benches are not recommended.

Technical data, Baselift

Model:	6200	6201	6202	6203
Arrangement	Straight	L-shape 45°	L-Shape 45°	L-shape 90°
Width	590 - 3400 mm	1050-2550 mm / side	1050-2550 mm / side	800-2500 mm / side
Worktop height, excl. top board	700 - 950 mm	700 - 950 mm	700 - 950 mm	700 - 950 mm
Depth, from wall, excl. front	560 - 580 mm	560 - 580 mm	560 - 580 mm	560 - 580 mm
Vertical stroke, max	250 mm	250 mm	250 mm	250 mm
Time for a lift or lowering stroke	ca. 20 sec.	ca. 20 sec.	ca. 20 sec.	ca. 20 sec.
Mains supply*	120 V 6 A / 230 V 2,5 A	120 V 6 A / 230 V 2,5 A	120 V 6 A / 230 V 2,5 A	120 V 6 A / 230 V 2,5 A
Power consumption 120V / 230V*	720 W / 575 W	720 W / 575 W	720 W / 575 W	720 W / 575 W
Max no. of full wok cycles per hour	5	5	5	5
Control voltage	24 V DC	24 V DC	24 V DC	24 V DC
Weight, suspended cabinets	15 kg / metre	15 kg / metre	15 kg / metre	15 kg / metre
Max load at the lift**	100 kg	100 kg	100 kg	100 kg

* The voltage depends on which model that is delivered.

** Top board and all other equipment must be included in the maximum load.

Note that the max. rated load means that the load is distributed over and inside the entire Worktop Lift. Point loads are not allowed.

4.1 Mechanical construction



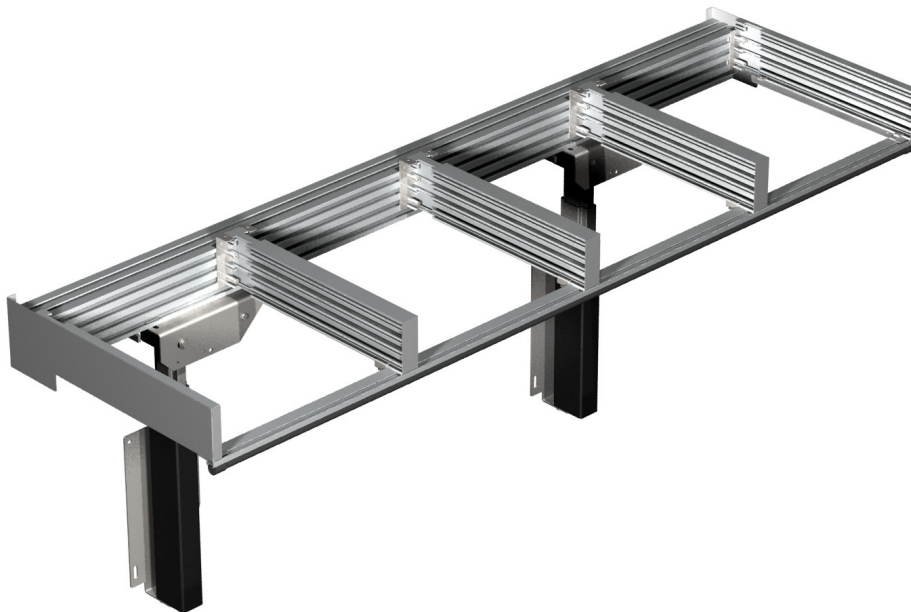

The worktop lift comprises wall mounted motors and a frame system in aluminium. Cover plates in white melamine, fronts and top board are accessories. Drawers, buttons, hob and sink can be mounted in the frame system.

The lift and lowering motion is achieved by electrically powered screw jacks which operate between the wall and the frame system.

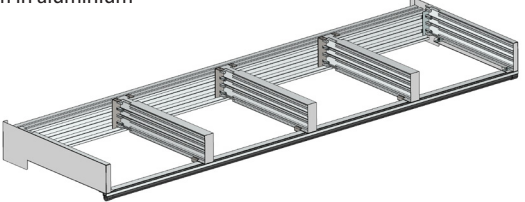

4.2 Delivery modules

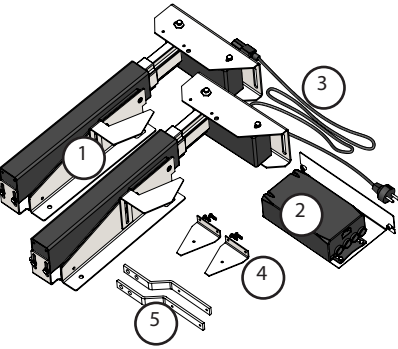
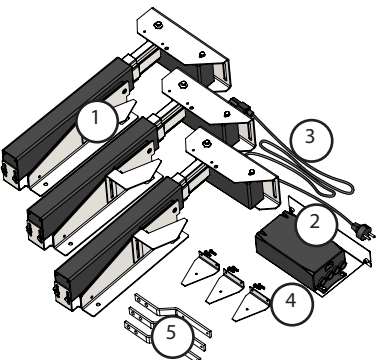
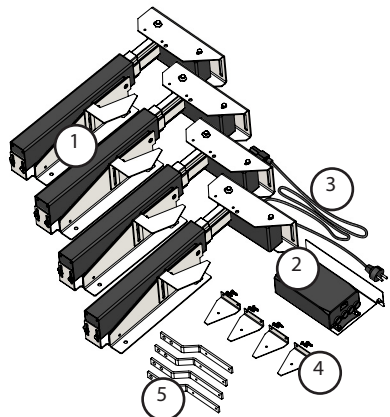
The Worktop lift unit is delivered in boxes. The components shall be assembled in accordance with the assembly instructions. The packaging material shall be handed over to an organized material re-cycling organisation.

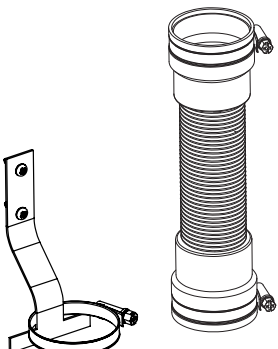
<p>Frame system in aluminium</p> 	<p>Push button (The button at the picture is used for recessed installation).</p> 	
<p>Motor package, 2 motors</p>  <ol style="list-style-type: none"> 1) Motor 2) Control box with connection for security strip 3) Electricity cable 4) Brackets for inner cover plate 5) Brackets for outer cover plate 	<p>Motor package, 3 motors</p>  <ol style="list-style-type: none"> 1) Motor 2) Control box with connection for security strip 3) Electricity cable 4) Brackets for inner cover plate 5) Brackets for outer cover plate 	<p>Motor package, 4 motors</p>  <ol style="list-style-type: none"> 1) Motor 2) 2x Control box with connection for security strip 3) Electricity cable 4) Brackets for inner cover plate 5) Brackets for outer cover plate
<p>Cover plates (accessories)</p> 	<p>Flexible water hoses (accessories)</p> 	<p>Flexible drain hose (accessories)</p> 

More examples of accessories:
Top board, hob, sink, mixer tap, drawers, chopping-board extra security strips.

4.3 Joist heights, location of electric socket, water and sewerage

Laying joists in the wall, electric sockets, water- and sewerage connections shall be positioned acc. the following table.

Work height:	Joist / attachment A-measure:	Joist / attachment B-measure:	Free mounting space under the lift:	Location of electric:	Location of water and sewer:	Tile height: Pos. E
700 - 950 mm*	154 mm**	434 mm**	100 mm	Pos. D***	Pos. D***	700 mm

* The measure is without top board.

** Lying joist behind the entire lift.

*** Max 100 mm above the floor. Free mounting space from wall to cover panels is 111 mm, see pos. F, picture 2.

Pic.1

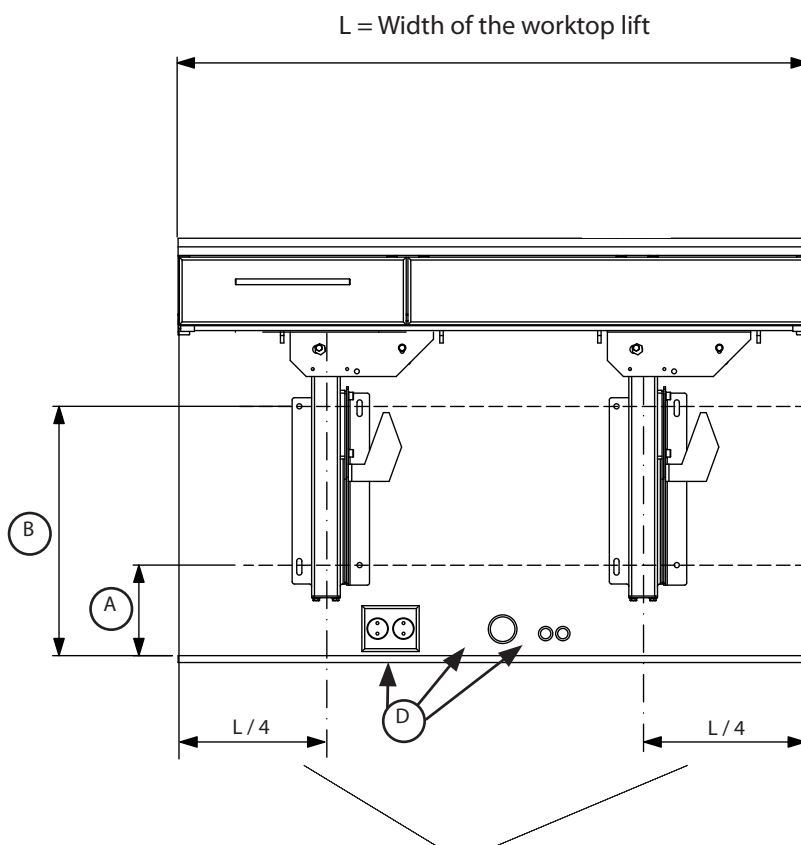

Pic. 2

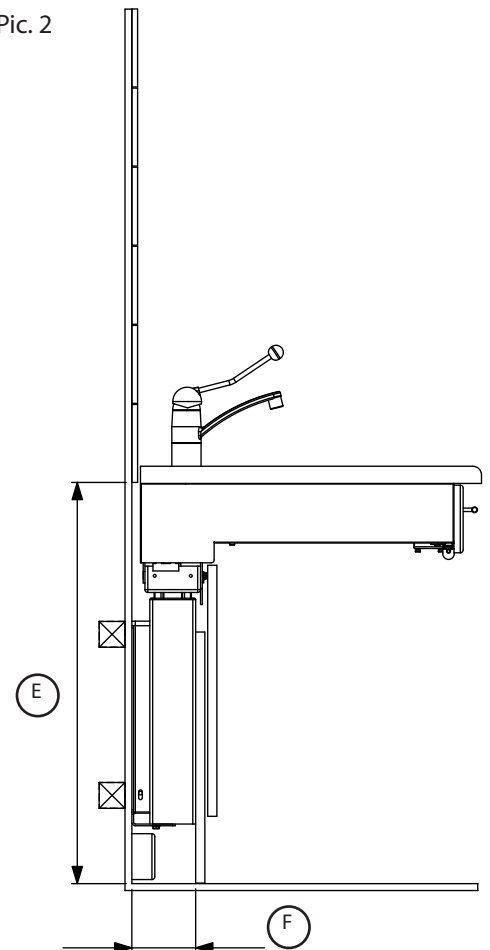

Location of the motors:

Divide the width of the lift by 4 to get the optimal measurement for location of the motors. This measurement is recommended but you have to consider water-, sewer- and electrical connections to avoid collisions.

Note!

Avoid to place the motors straight under the mixer tap since it then can be hard to get enough space behind the cover plates for the sewer pipes.

Example:

Total width 2000 mm. Place the motor 500 mm from the outer edge. ($2000 / 4 = 500$)

4.4 Electric connections

The Worktop lift unit shall be connected to a separate mains switch, which is placed in the kitchen or its vicinity. The socket for 230 V, 50 Hz / 120 V 60 Hz shall be placed acc. section 4.3.

* Power consumption 720 W (120 V) or 575 W (230 V)



An authorized electrician must make the electric installation!

4.5 Water- & sewer connections

Note!

Professionals must make the connection of the water and sewer pipes, to prevent water damages. It is important that the right materials are used, and that location and fixing is made properly. The use of Granberg original installation materials, and the instructions in this manual, ensures correct execution, if a competent fitter carries out the installation work. Make sure that the carpet is going up at the wall a bit to prevent water damages if there should be leakage.

Water connection

The water connection shall be made to a 1/2" ballofix coupling. See section 4.3 for correct location.

Note!

Fix the pipes with the clamp **(A)** in the aluminium frame. Connect flexible water hoses between the pipes from the mixer tap to the ballofix coupling.

Run the lift and check that the hoses moves freely.

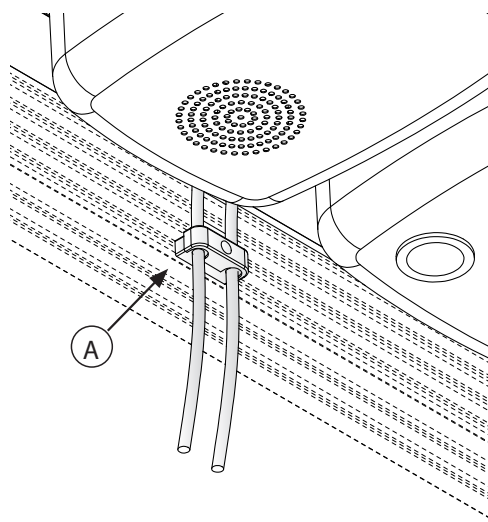

Flexible drain connection

Follow the instructions supplied with the flexible drain hose 61801 (accessory).

4.6 Installation of straight worktop lift series 6200



Note!

- * Tiles shall be mounted on the wall prior to installation of the worktop lift unit.
- * To facilitate the side wise positioning the cabinets are installed on one side of the worktop lift unit prior to installing this.
- * There shall be a space of 5-8- mm to adjacent cabinets or walls on both sides of the Worktop lift.
- * See section 4.3 for correct height positioning of the motors.

Competent persons must make the installation work!

4.6.1

Measure and mark the position side wise of the motors.
(See page 7, for correct position)

Place the mounting blocks **(A)** at the floor. Place the motors at the mounting block and screw into the wall through the oval holes.

To be able to adjust later, don't use the round holes at this moment.

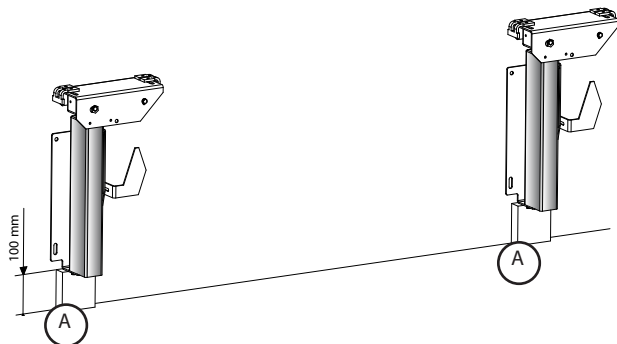

4.6.2

Place the frame system at the motors and tighten the screws slightly. Adjustment will be done later.

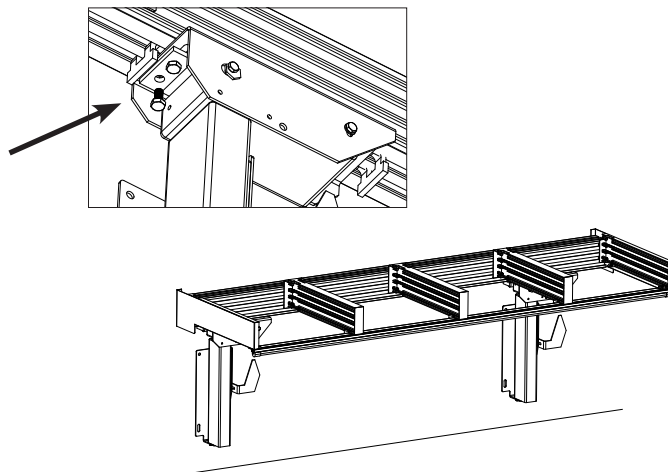

4.6.3

Mount the control box in the middle, under the aluminium bar.
Extension cables are included if the width of the worktop lift is over 180 cm.

Screw the control box into the wall between the motors (55 cm over the floor) if the width of the lift is less than 100 cm.

(Mount the control box with the cable connections turned down).

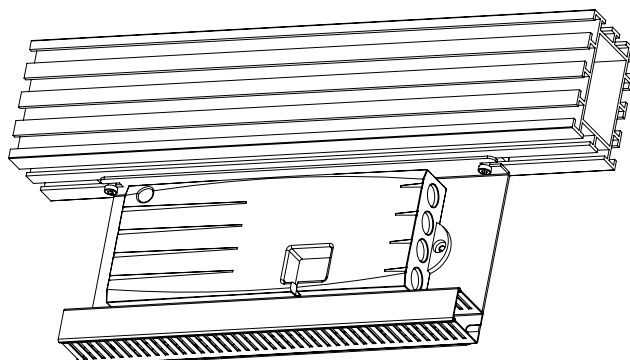

4.6.4

Connect the motors, the security strip, push button and the electricity cable according the instructions below.

Synchronise the motors:

Run the lift to it's lower position and hold the button (at least 5 sec.) until you hear a click from the control box. The synchronisation has succeed when you hear the click sound.

Run the lift up and down and check that the motors are moving at the same time.

Note!

The security strip must be connected to be able to run the lift.

Run the lift to it's highest position.

1. Connect the motors

2. Connect the security strip

3. Connect the push button

4. Connect the electricity

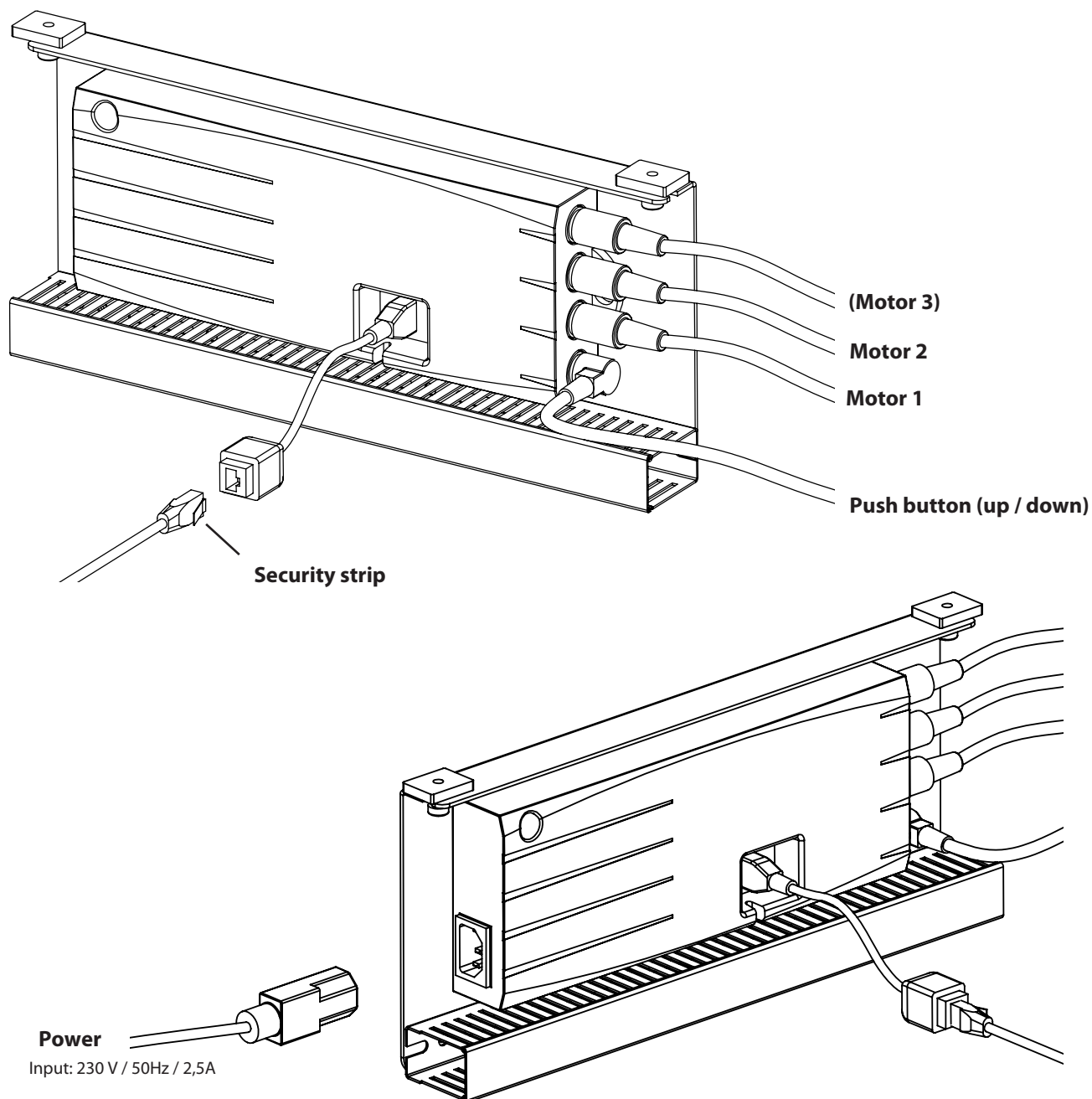

4.6.5

Adjust the aluminium frame in depth and side wise.

Adjust the depth so it suits with the rest of the kitchen.
(The depth is adjustable between 560 to 580 mm).

Lock the position when the adjustment is ready.
See sketch below.

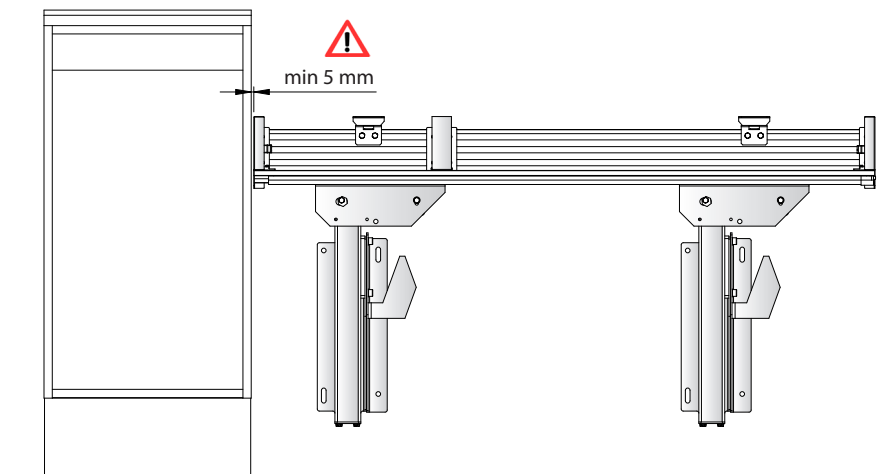
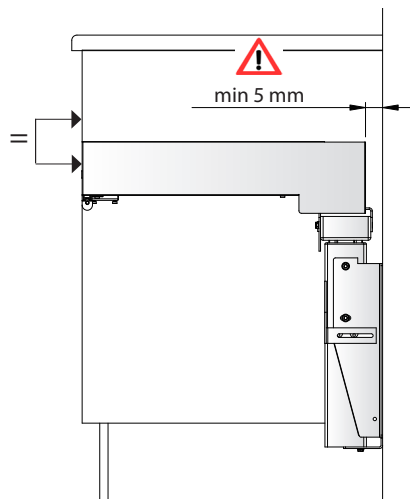
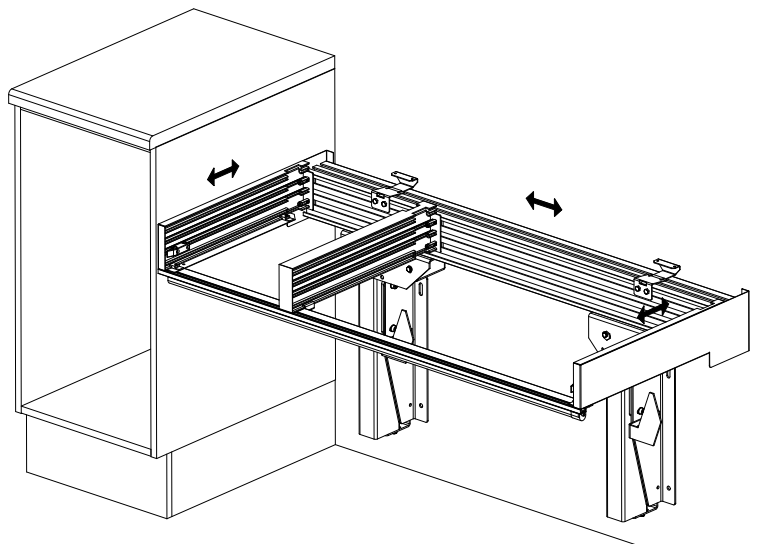

**Tighten the screws between the motors and the aluminium frame when the adjustment is ready.
4 screws per motor.**

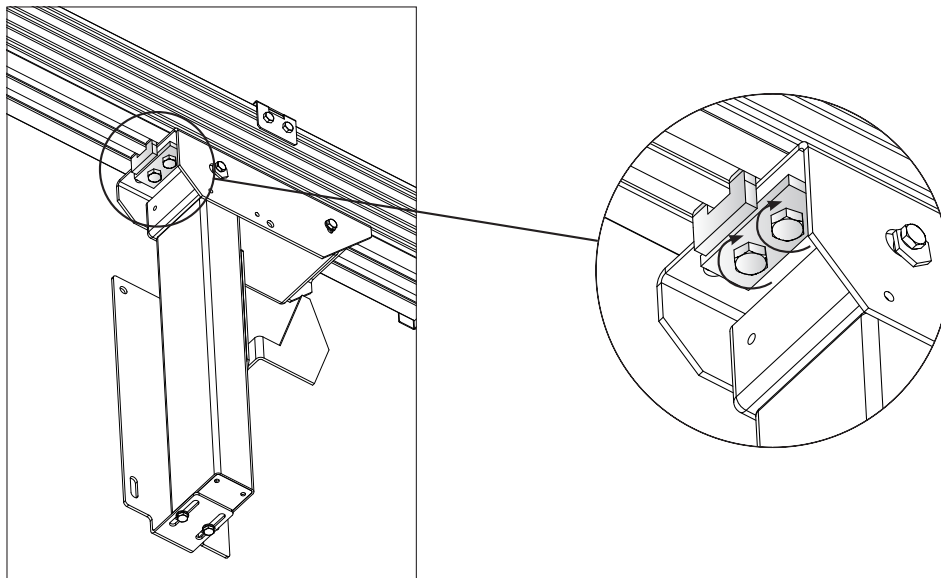

4.6.6

Check that the upper part of the lift is exactly horizontally levelled with a water level.

To adjust:

- * Loosen slightly the screws from the wall to be able to adjust the motors vertically.
- * Screw into the wall through the round holes to fix the position of the motors.

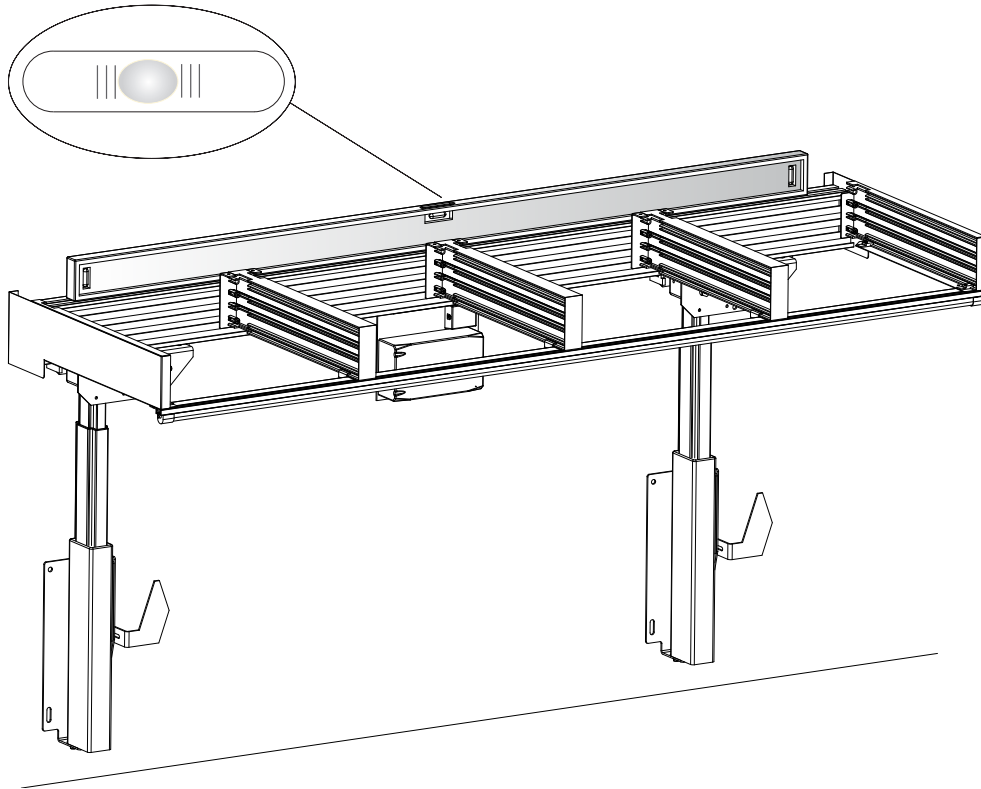

Go to page 20 to mount the accessories.

After installation a complete functional test with full load shall be made! (See section 4.16)

4.7 Installation of worktop lift unit L-shaped with 45° corner, series 6201 & 6202.

6201



6202



Note!

- * Tiles shall be mounted on the wall prior to installation of the worktop lift unit.
- * To facilitate the side wise positioning the cabinets are installed on one side of the worktop lift unit prior to installing this.
- * There shall be a space of 5-8- mm to adjacent cabinets or walls on both sides of the Worktop lift.
- * See section 4.3 for correct height positioning of the motors.

Competent persons must make the installation work!

4.7.1

Mount the aluminium frame at the floor as shown below.

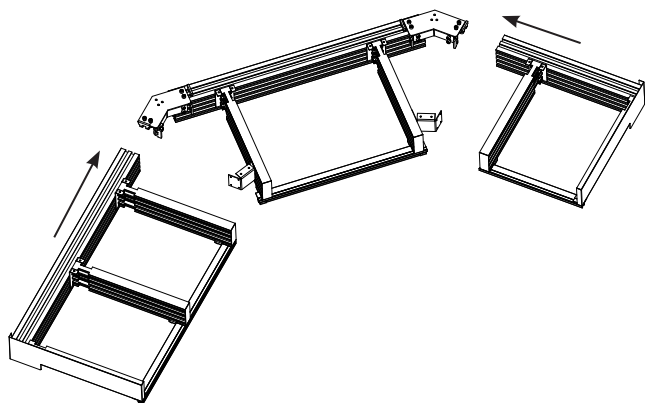

4.7.2

Place the aluminium frame at the floor in the corner. Measure and mark the position side wise of the motors. (See page 7, for correct position)

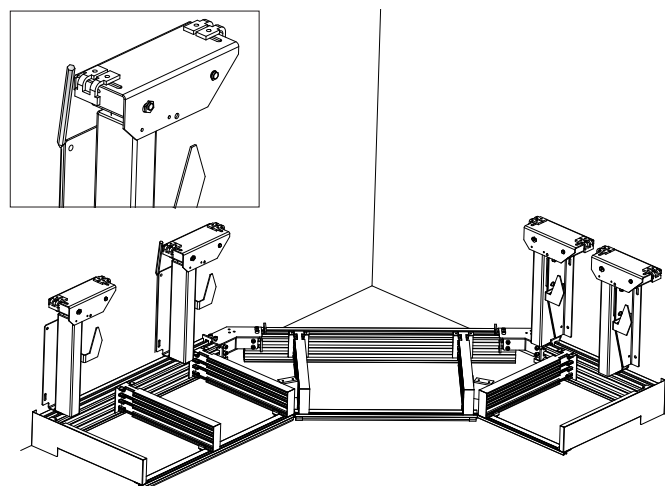

4.7.3

Place the mounting blocks (A) at the floor. Place the motors at the mounting block and screw into the wall through the oval holes.

To be able to adjust later, don't use the round holes at this moment.

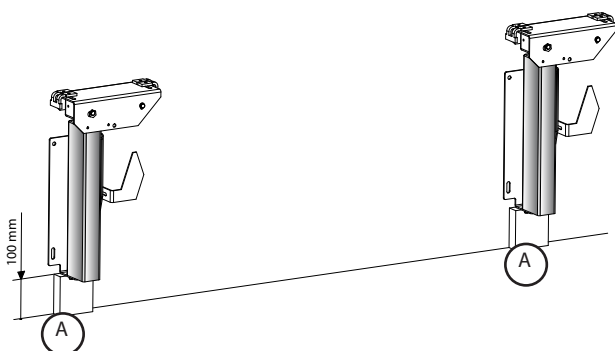

4.7.4

(ONLY WORKTOP LIFT 6201)

Mount the corner support for top board.

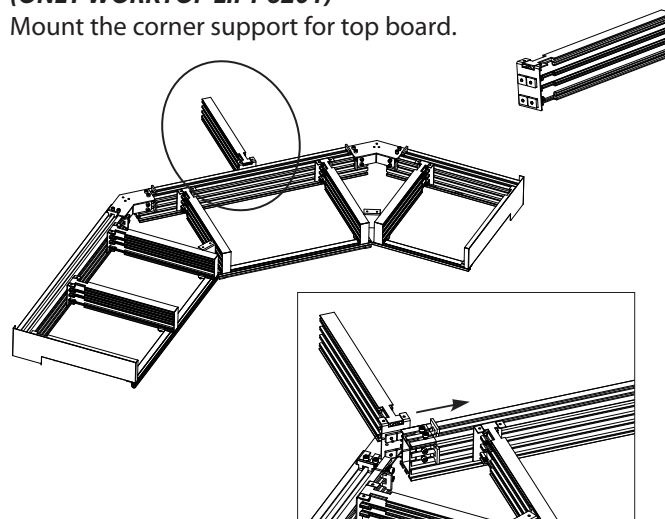

4.7.5

Place the frame system at the motors and tighten the screws slightly. Adjustment will be done later.

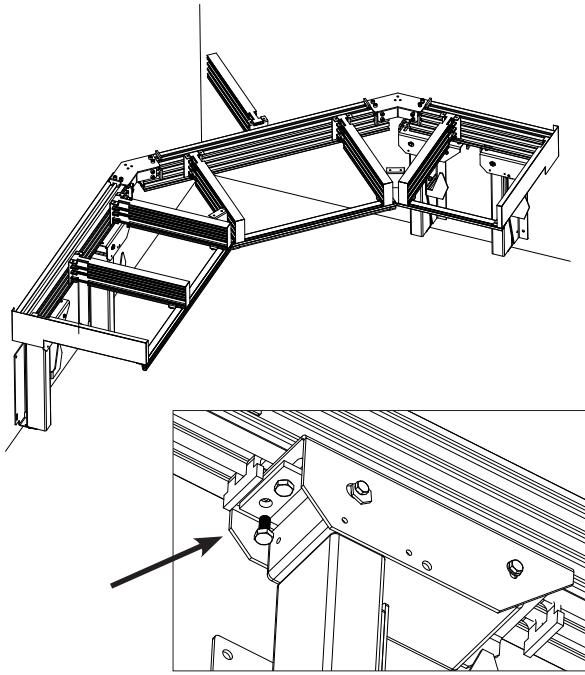

4.7.6

Mount the control box between the motors under the aluminium bar.

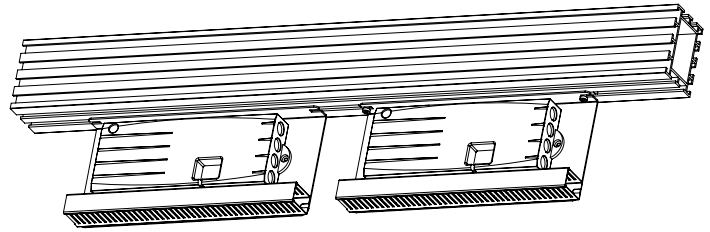

4.7.7

Connect the motors, the security strip, push button and the electricity cable according to the instructions below.

Synchronise the motors:

Run the lift to its lower position and hold the button (at least 5 sec.) until you hear a click from the control box. The synchronisation has succeeded when you hear the click sound.

Run the lift up and down and check that the motors are moving at the same time.

Note!

The security strip must be connected to be able to run the lift. Run the lift to its highest position.

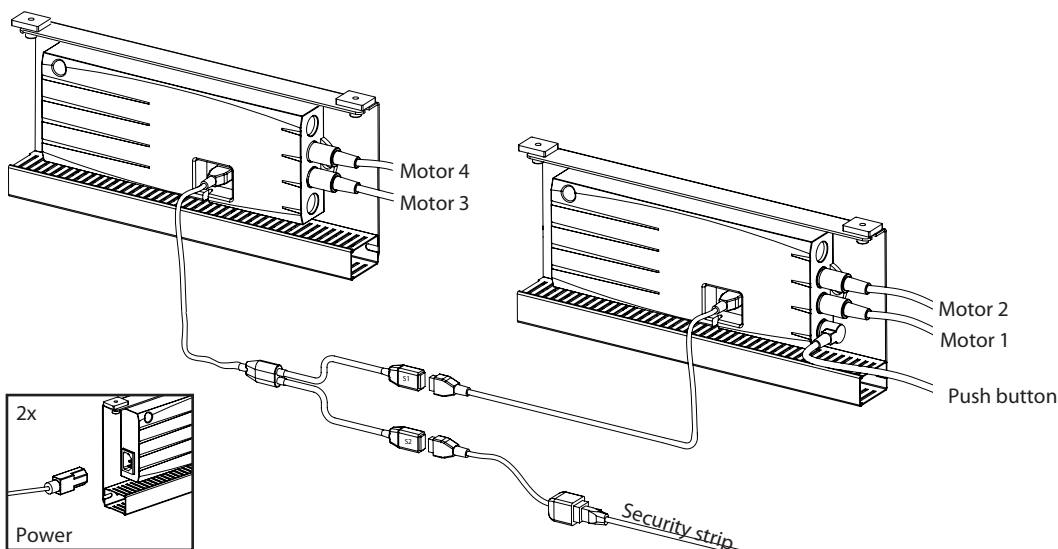

4.7.8

Adjust the aluminium frame in depth and side wise.

Adjust the depth so it suits with the rest of the kitchen.
(The depth is adjustable between 560 to 580 mm).

Adjust the width so it suits the measurement of the top board.

Lock the position when the adjustment is ready.
See sketch below.

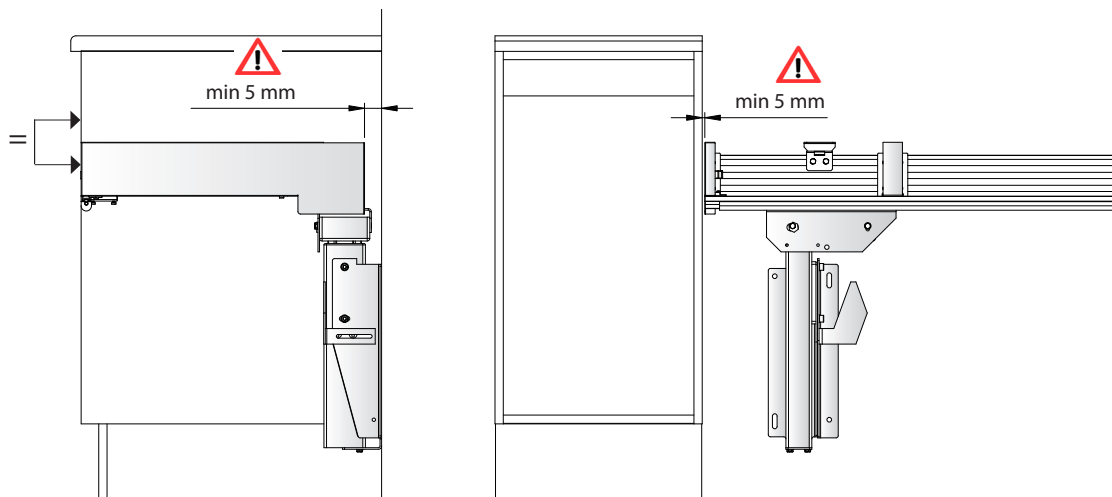
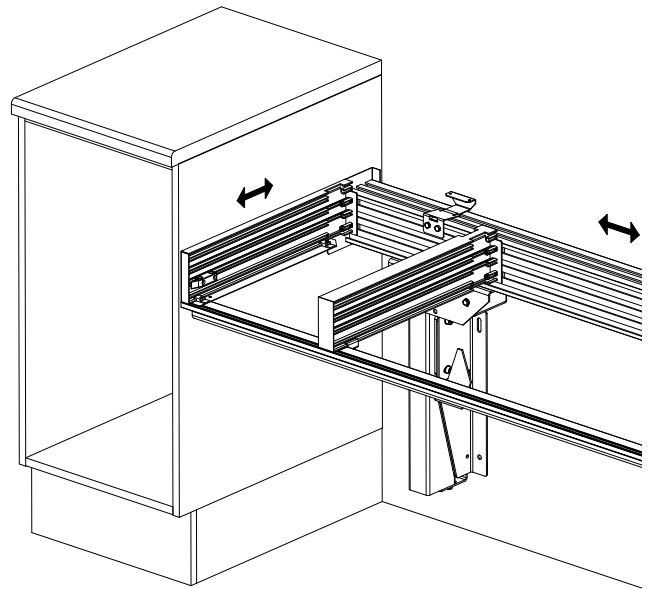

**Tighten the screws between the motors and the aluminium frame when the adjustment is ready.
4 screws per motor.**

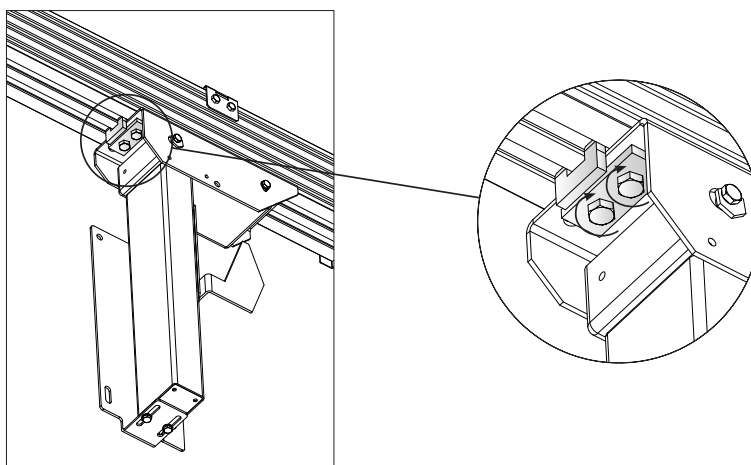

4.7.9

Check that the upper part of the lift is exactly horizontally levelled with a water level.

To adjust:

- * Loosen slightly the screws from the wall to be able to adjust the motors vertically.
- * Screw into the wall through the round holes to fix the position of the motors.

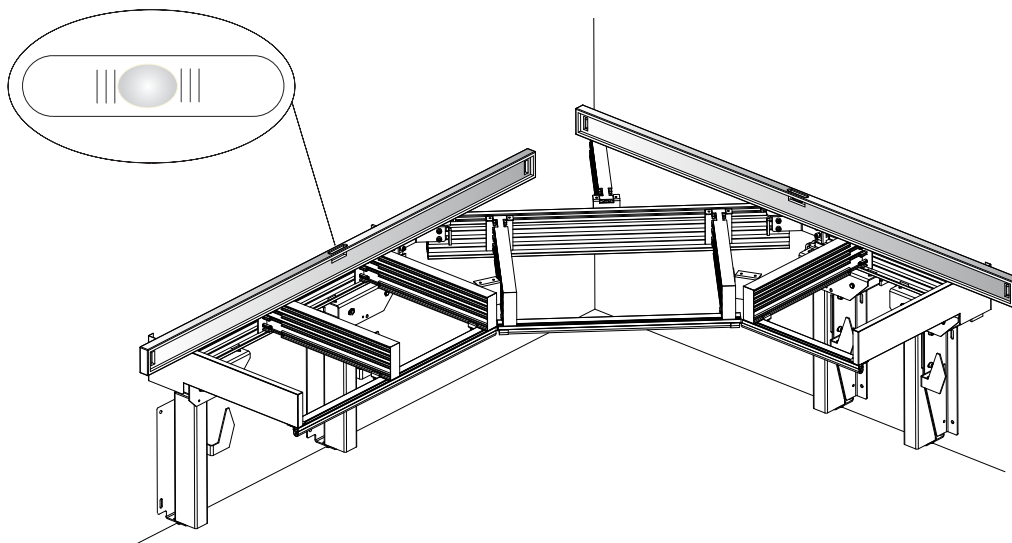

4.7.10

(ONLY WORKTOP LIFT 6201)

Mount the brackets to the outer cover plate in the corner.

Adjust the depth position of the brackets when the cover plates are mounted.

1.

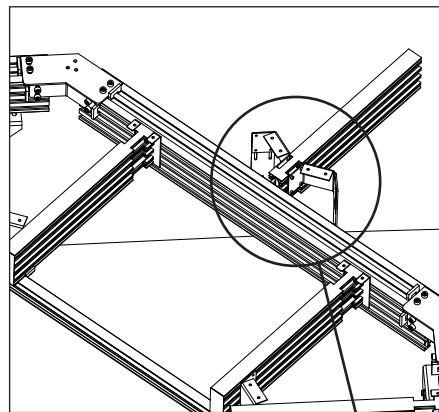

2.

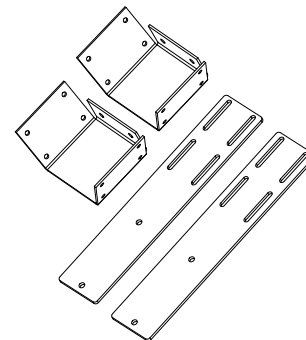
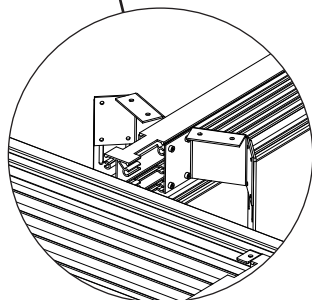
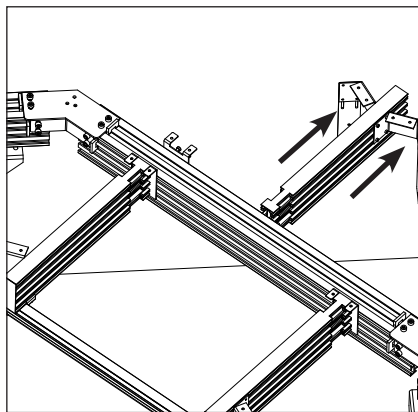

Go to page 20 to mount the accessories.

After installation a complete functional test with full load shall be made! (See section 4.16)

4.8 Installation of worktop lift unit L-shaped with 90° corner, series 6203



Note!

- * Tiles shall be mounted on the wall prior to installation of the worktop lift unit.
- * To facilitate the side wise positioning the cabinets are installed on one side of the worktop lift unit prior to installing this.
- * There shall be a space of 5-8- mm to adjacent cabinets or walls on both sides of the Worktop lift.
- * See section 4.3 for correct height positioning of the motors.

Competent persons must make the installation work!

4.8.1

Mount the aluminium frame at the floor as shown below.

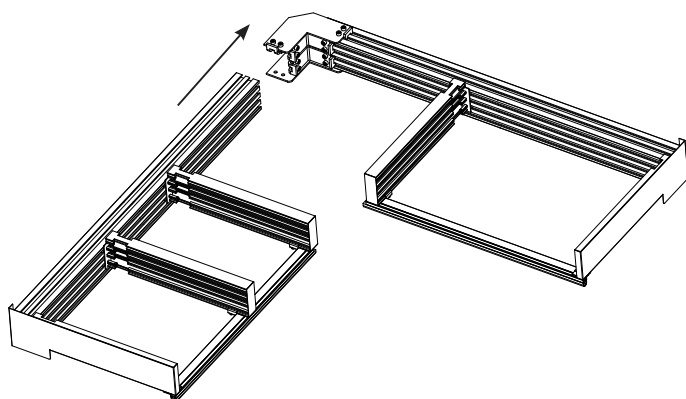

4.8.2

Place the aluminium frame at the floor in the corner. Measure and mark the position side wise of the motors. (See page 7, for correct position)

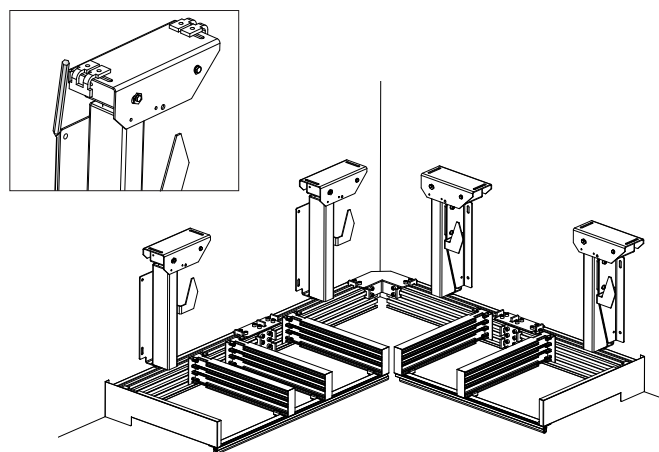

4.8.3

Place the mounting blocks (A) at the floor. Place the motors at the mounting block and screw into the wall through the oval holes.

To be able to adjust later, don't use the round holes at this moment.

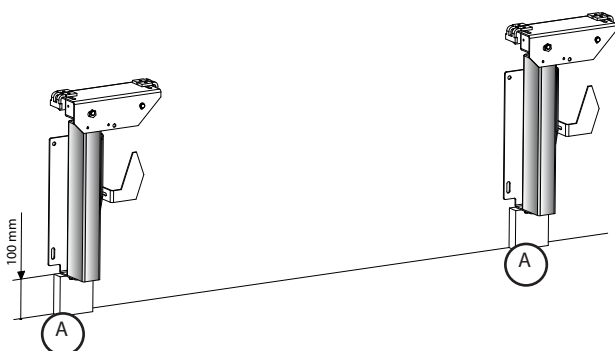

4.8.4

Place the frame system at the motors and tighten the screws slightly. Adjustment will be done later.

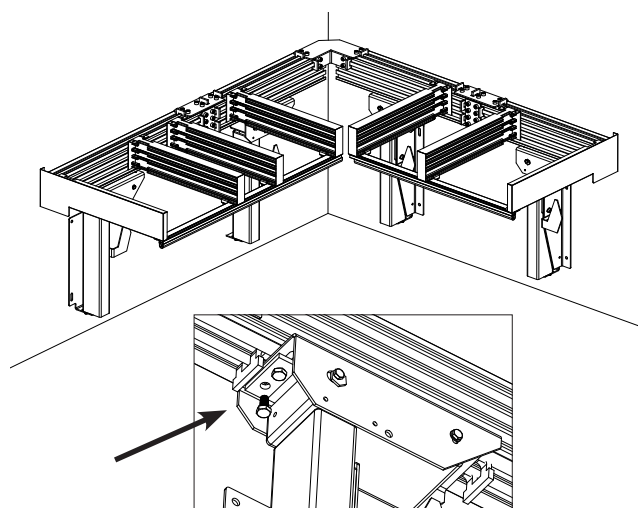

4.8.5

Mount the control box between the motors under the aluminium bar.

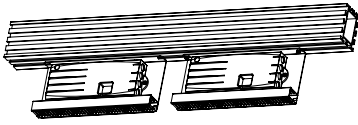

4.8.6

Connect the motors, the security strip, push button and the electricity cable according to the instructions below.

Synchronise the motors:

Run the lift to its lower position and hold the button (at least 5 sec.) until you hear a click from the control box.

The synchronisation has succeeded when you hear the click sound.

Run the lift up and down and check that the motors are moving at the same time.

Note!

The security strip must be connected to be able to run the lift. Run the lift to its highest position.

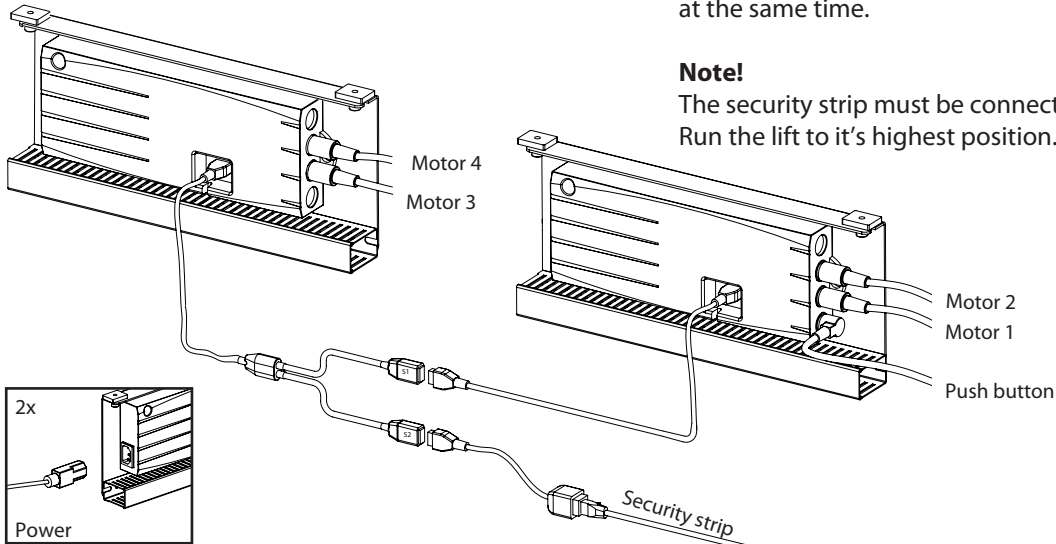

4.8.7

Adjust the aluminium frame in depth and side wise.

Adjust the depth so it suits with the rest of the kitchen.
(The depth is adjustable between 560 to 580 mm).

Adjust the width so it suits the measurement of the top board.

Lock the position when the adjustment is ready.
See sketch at the next side.

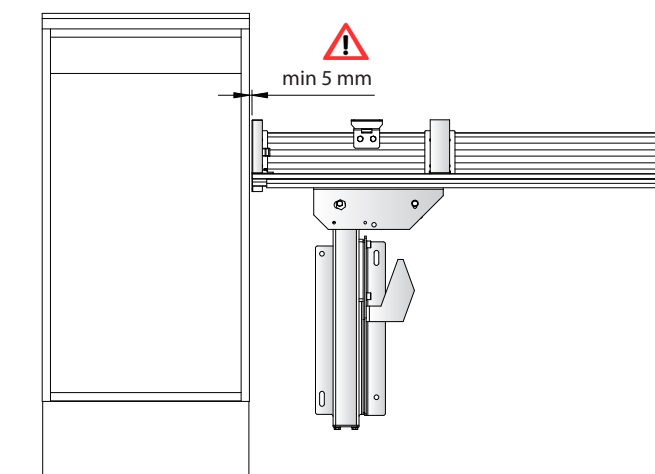
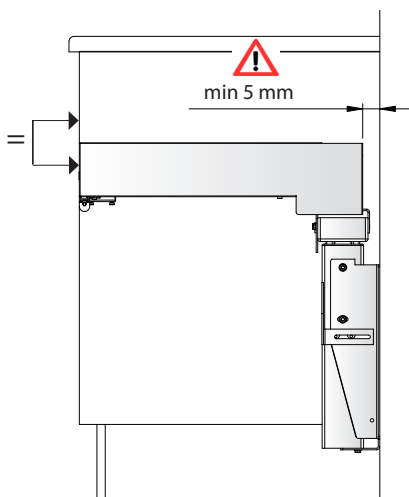
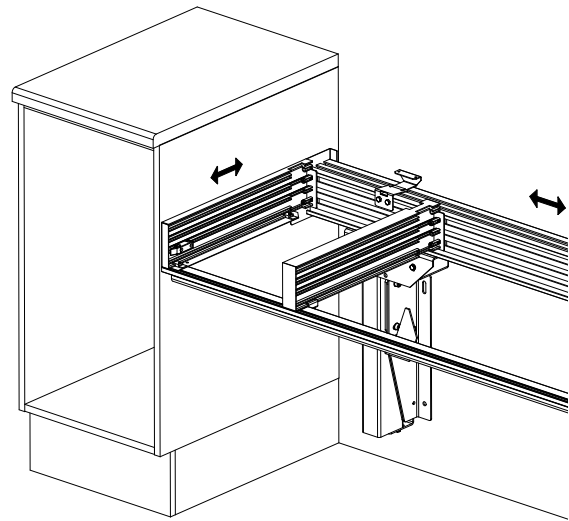



**Tighten the screws between the motors and the aluminium frame when the adjustment is ready.
4 screws per motor.**

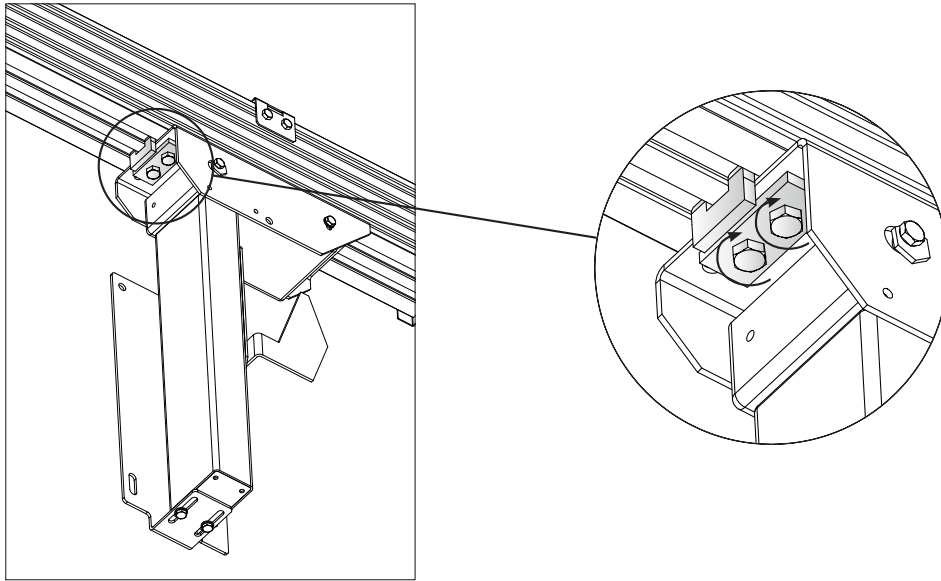

4.8.8

Check that the upper part of the lift is exactly horizontally levelled with a water level.

To adjust:

- * Loosen slightly the screws from the wall to be able to adjust the motors vertically.
- * Screw into the wall through the round holes to fix the position of the motors.

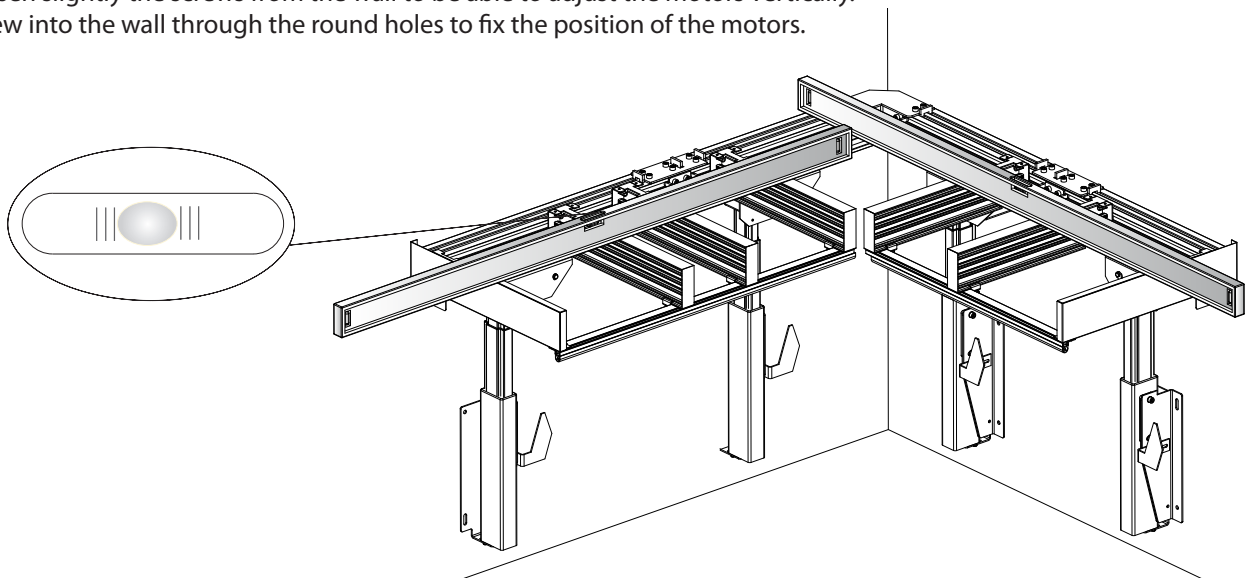

Go to page 20 to mount the accessories.

After installation a complete functional test with full load shall be made! (See section 4.16)

4.9 Installation of fronts

(You can ignore the information below if Granberg has delivered drawers and fronts. The positions of the sides in the aluminium frame are then correct adjusted).

If you need to adjust the sides to fit you fronts and drawers:

Loosen 6 screws in the aluminium beam and 2 screws under the aluminium profile that is holding the security strip.

Adjust the sides side wise to the correct position and lock the position.

Brackets and screws to mount the fronts at the aluminium frame are included in the delivery. Mount the screws at the back of the fronts. See measurements according to the picture below.

(mm)

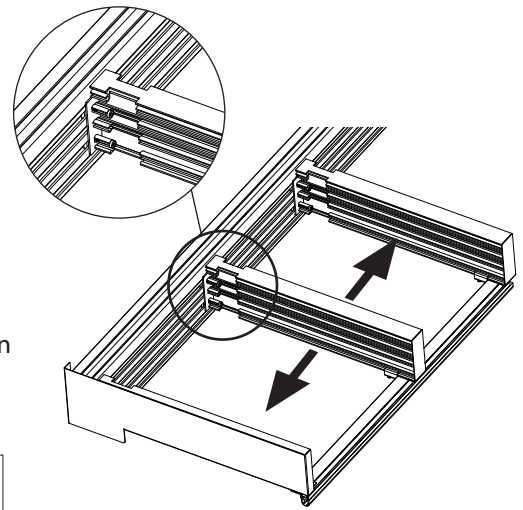
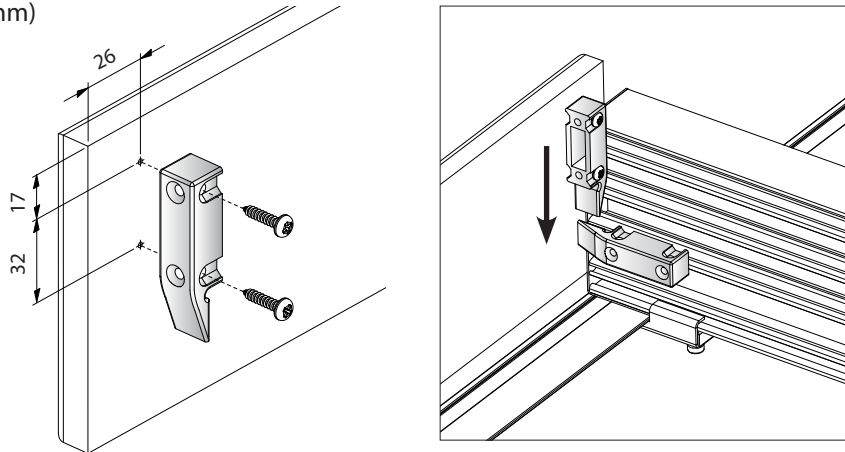

4.10 Installation of push button ALU

The position of the push button is chosen together with the person that is going to use the worktop lift.

Use a 60 mm drill to make the hole in the front. The measure from the centre of the hole to the edge of the front are not allowed to be less than 100 mm.

It is a good idea to place push buttons next to each other if several lifting systems from Granberg are used in the same kitchen.

Two- or three-compartment frame are then used instead of one-compartment frame (2).

The distance between the holes shall be 72 mm centre - centre.

Power switch can also be used in combination with buttons. Power switch must be mounted together with a damp-proof cover that is delivered from Granberg. The hole for power switch shall be 73 mm.

Note that the inner part of the push button (1) shall be mounted with the text "TOP, OBEN" downwards.

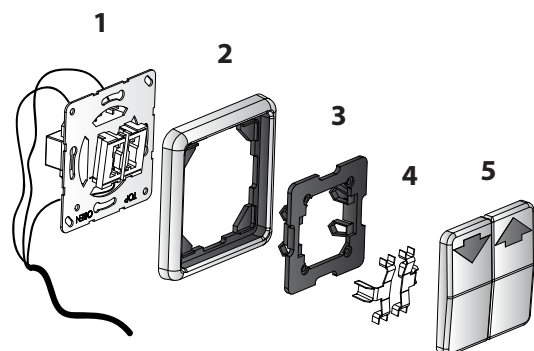
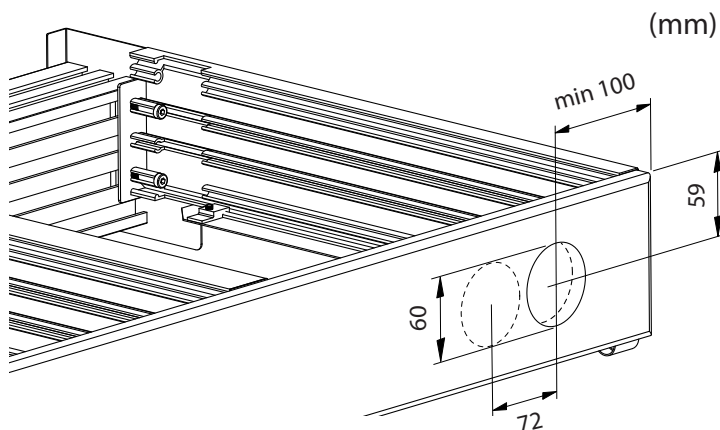
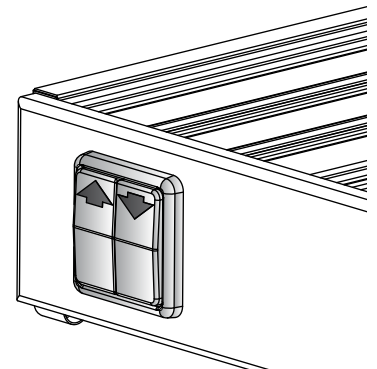

4.11 Mounting of the Alu rear edge

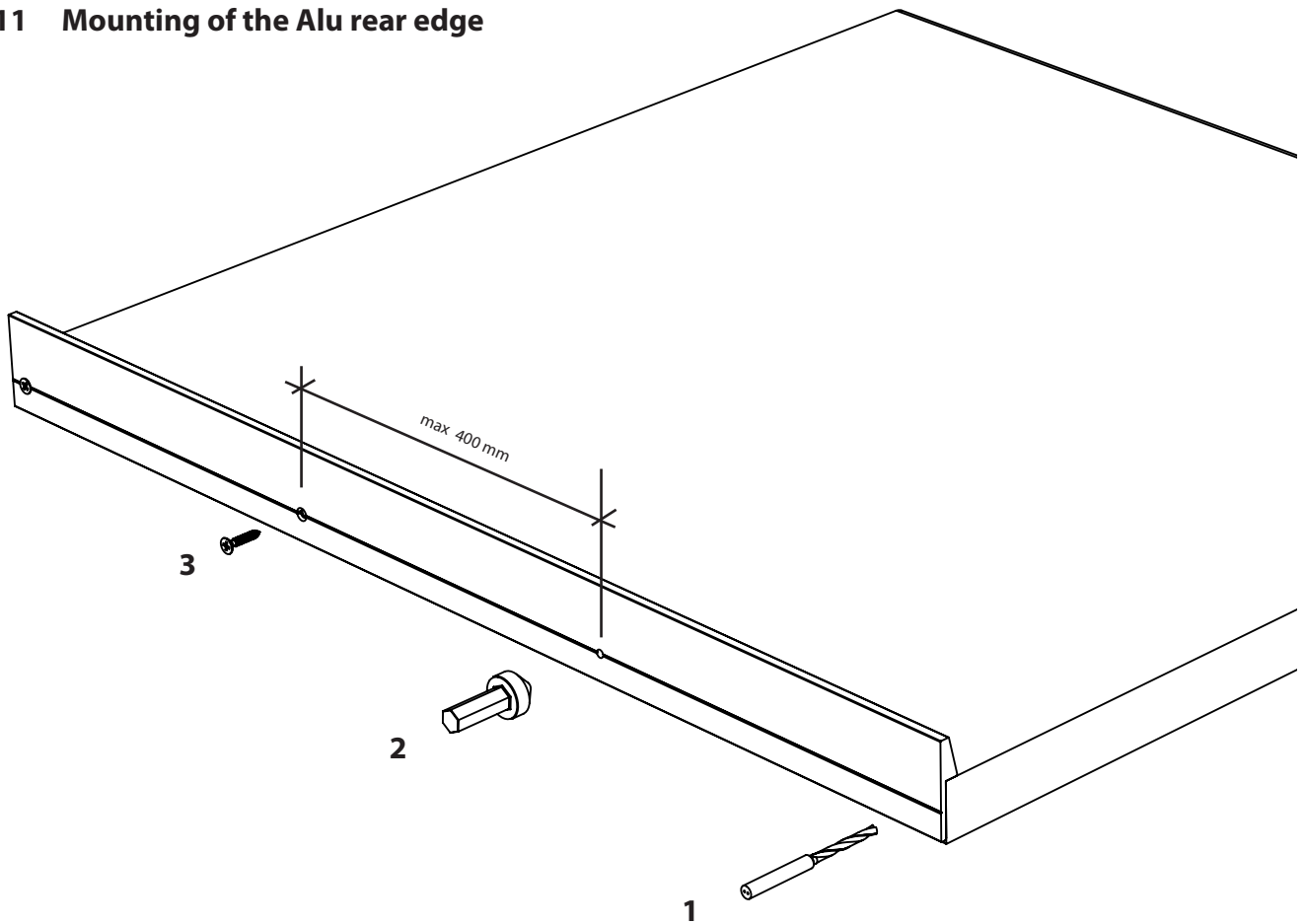

4.12 Mounting of top board

Place the top board at the worktop lift and mark where hob and sink are going to be placed.

Note!

**Do not saw in the top board when it is placed at the aluminium frame.
The worktop lift can be damaged!**

Fix the position of the top board in the aluminium frame by use of enclosed brackets and screws. Adjust the top board so the front edge is in the same position as the adjacent top boards.

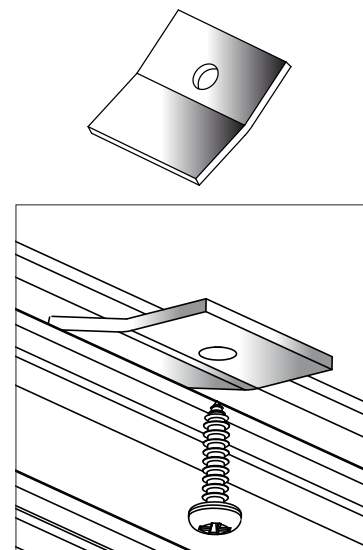
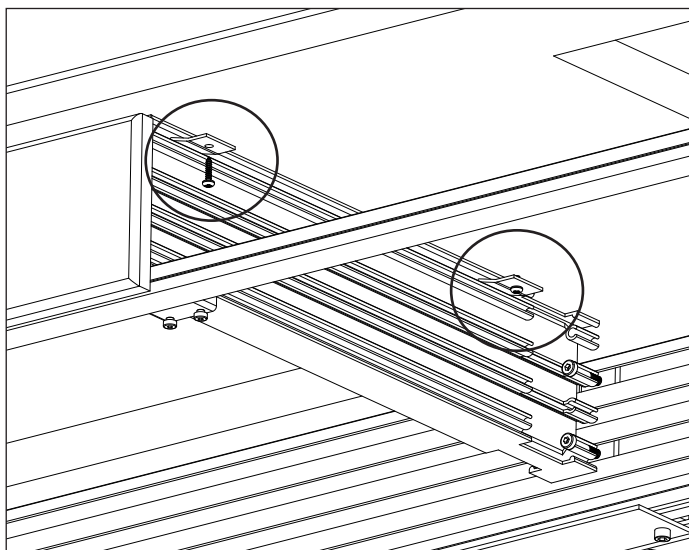
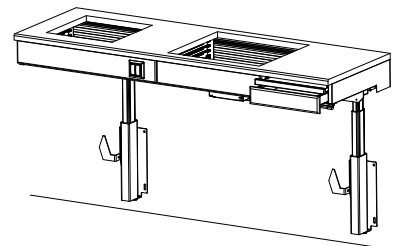

4.13 Mounting of complete sink units (not inset sinks)

**Granberg worktop lifts do only suit complete sinks delivered from Granberg.
(These sinks are special made to suit the worktop lift)**

Do always contact granberg before use of a complete sink that is not delivered by Granberg.
See section 4.5 for correct drain connection.

Things to note if the sink is not delivered from Granberg:

The depth of the sink must be maximum 120 mm. The function of the security strip does not work by use of deeper sinks.

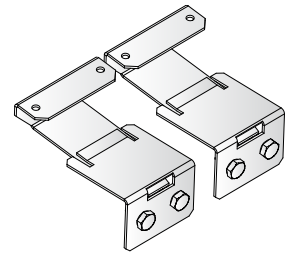

Mount the support bracket in the back of the sink.

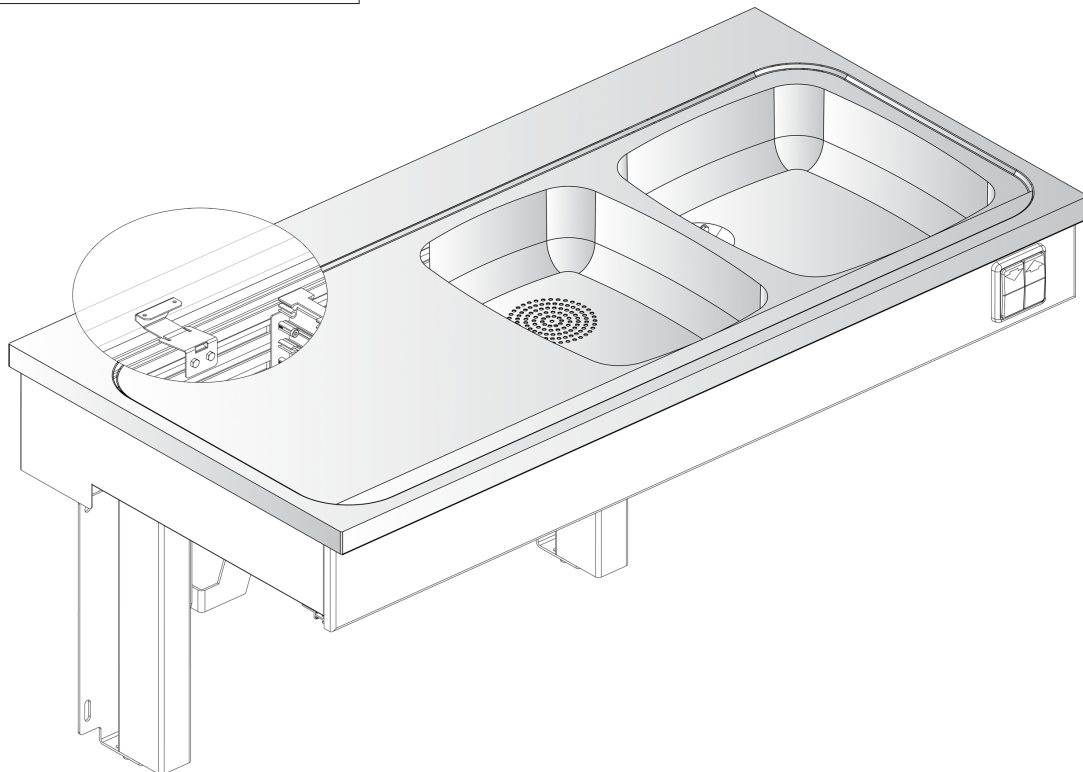
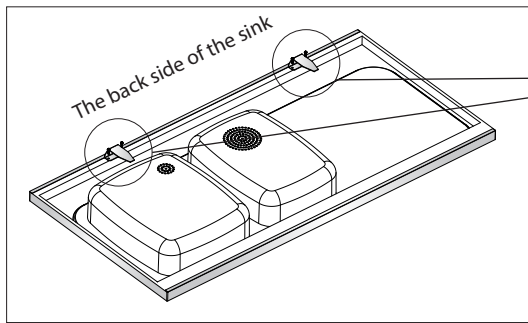

Fix the front edge of the sink at the left and right edges.

In some cases it is easier to remove the front to be able to reach.

4.14 Mounting of cover plates, 6260-XXXXX

The cover plates are two plates, one placed at the floor and one that is following the movement of the worktop lift.

The upper and lower cover plate has the same dimension. The thickness of the plate can be 12 - 16 mm.

If cover plates are not ordered from Granberg, see dimensions according to the sketch to the right.

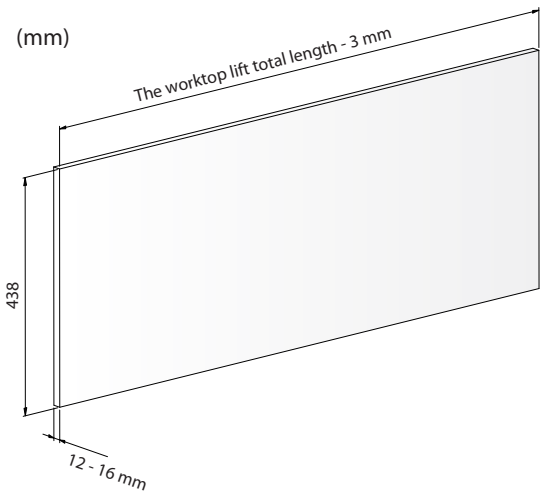

4.14.1

Mounting of the lower cover plate

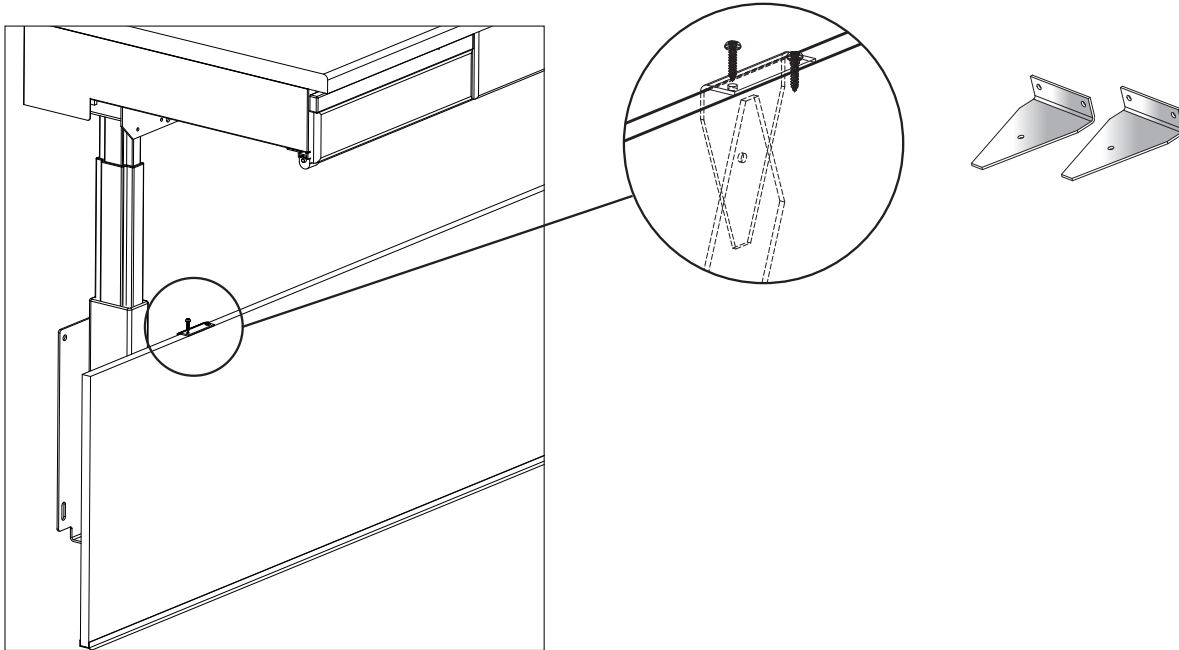

4.14.2

Mounting of the upper cover plate

(mm)

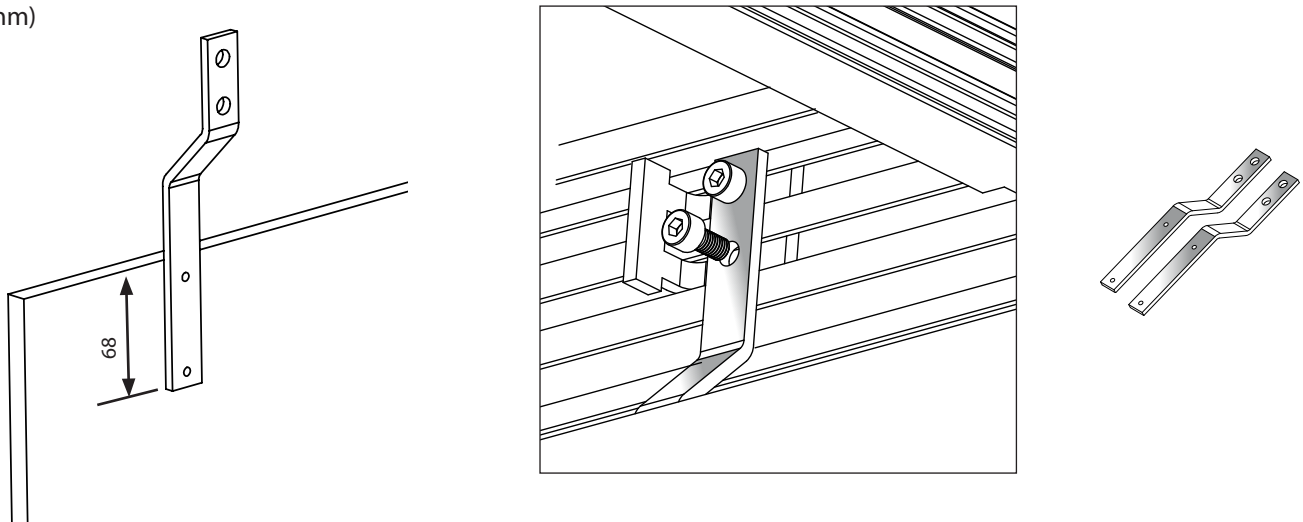

4.14.3

Mounting of the lower cover plate if it is divided. (This is for worktop lifts wider than 2400 mm).

Use the enclosed mounting brackets to fix the plates into the wall.

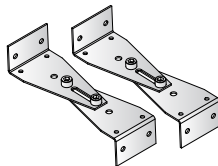
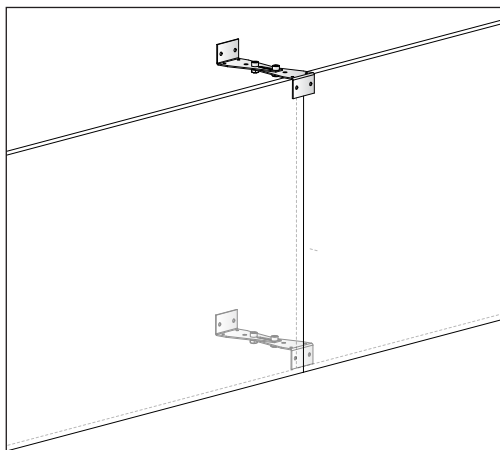

4.14.4

Mounting of cover plates in corner, model 6201, 6202 and 6203.

Mount the angles between the cover plates.

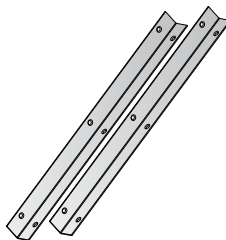
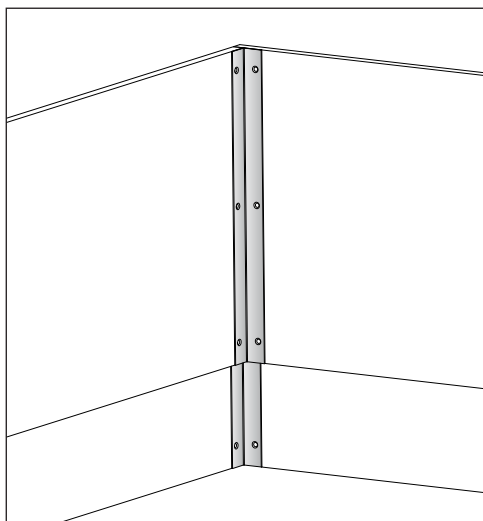

4.14.5

Mounting of cover plates in corner, model 6202.

Mount the angles between the cover plates.

4.15 Mounting of end covers to cover plates, 6270-06

1. Mount the lower end cover with the bending inwards See picture 1.
2. Mount the upper end cover with the bending outwards. See picture 2.

Run the lift up and down all the way to respectively end position. Check that the end covers moves freely, without hindrance and jarring sounds.

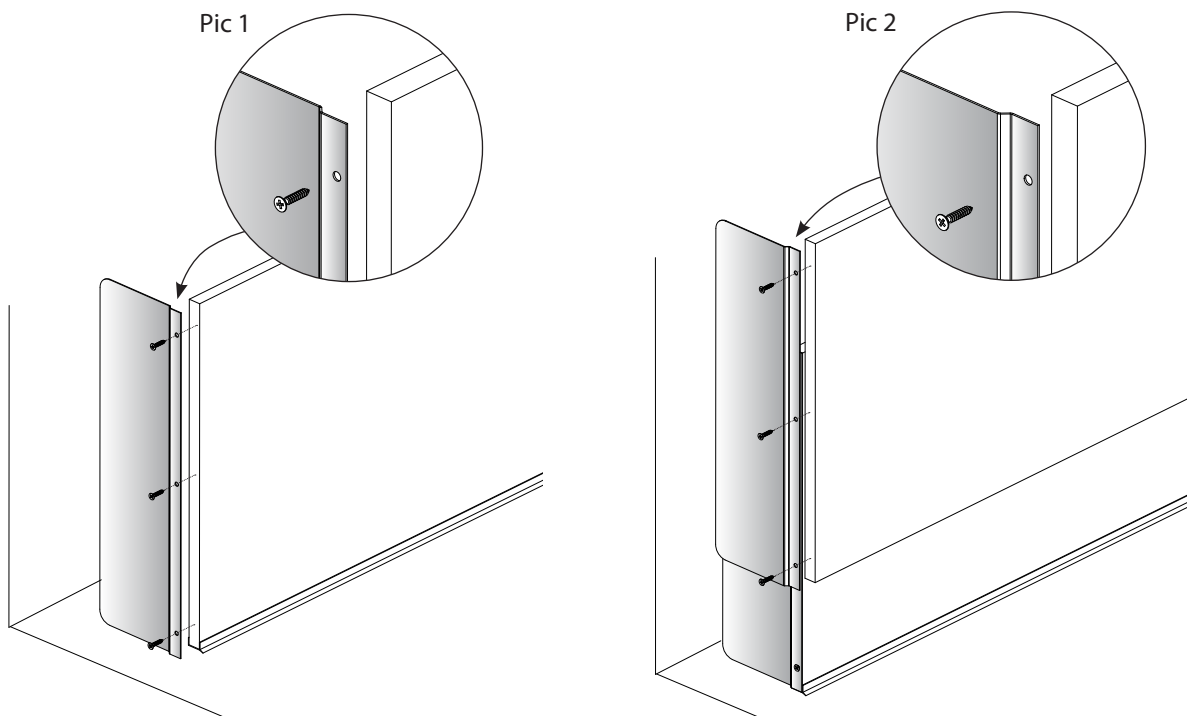

4.16 Functional test

After installation a complete functional test with full load shall be made:

- * Run the worktop lift unit down and up all the way to respectively end position and make the following checks:
Check that it moves freely, without hindrance and jarring sounds.
Check that it stays in the lowest resp. top positions.
Check that the motors are moving at the same time.
Check that no cables are jammed.
- * Lower the worktop lift unit and check that the security strip under the aluminium frame works properly, by means of pressing lightly onto it. The worktop lift shall stop immediately.
- * Adjust the inclination of the worktop board if necessary. See instructions below.

4.17 Adjust the inclination of the worktop lift

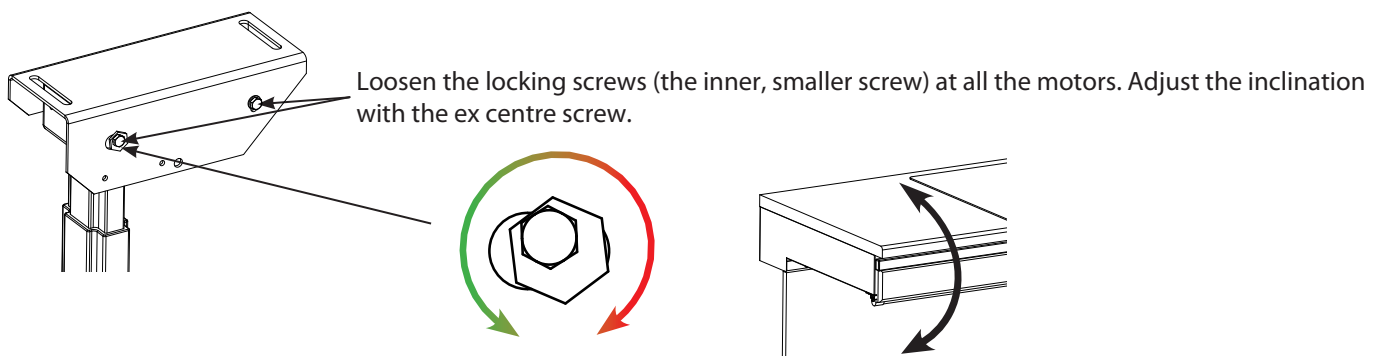

5.1 Safe use

The Worktop lift unit is provided with safety arrangements in order to prevent and avoid damages and accidents. It is however still very important that the operator is well instructed in how to install and operate the Worktop lift unit. In the following the Worktop lift unit means the lifting machine and the fitted accessories, such as drawers and chopping boards.

- Only use the Worktop lift unit for its intended purpose.
- The operation and use must be made in such way that there is no risk for damages on persons and property.
- The Worktop lift unit may only be operated by persons who have read and understood these instructions, and are authorized to use it.
- Be aware of that you as an operator are responsible for that nobody is damaged.
- The Worktop lift unit and the work area must be in proper condition. The Worktop lift unit must not be used if any fault has appeared which influences the functions or the operation safety. It shall also not be used if it has been repaired, altered or adjusted without permission of a responsible person.
- Do not touch any part of the lift when operating it. Only press the button for desired motion direction.
- Do not put hands, arms, or any other part of the body or any object under the worktop or the cabinets when it is operated.
- Do not operate with drawn out drawers or chopping boards.
- Do not raise the Worktop lift unit unless the space above it is free from persons or obstacles. In particular if the Worktop lift unit is installed under a Wall cabinet lift with adjustable height there is an imminent risk that you do not notice objects or equipment that might be trapped.
- Notice the jamming risk between the Worktop lift units and adjacent worktops and cabinets.
- Only stable and securely loaded items may be handled. Mind the tilting risk for objects on the worktop, which are unstable, e.g. carelessly piled.
- Safety devices must not be taken out of service or removed.
- Alterations of the Worktop lift unit that influence the operational safety or the functions are not allowed.
- Do not overload the Worktop lift unit and make sure that the load distribution is correct.
- It is absolutely forbidden for persons to stay on the worktop, to stand on extended drawers and chopping boards or to use the lift for lifting persons.
- Always distribute the load uniformly on the worktop, to avoid cantilevered loading. Consider the risk that the load can roll, slide or fall over.
- Use safe and sufficient lifting methods when handling load to and from the Worktop lift unit. In particular beware when handling heavy items, and goods with hazardous content or with sharp corners and edges.
- Be aware of the risks when you work on Worktop lift unit. The risks are depending on the arrangements on the worktop.
- The Worktop lift unit shall regularly, once a year, be inspected in order to prevent accidents.
- Applicable Building and Safe use Regulations must be complied with.
- Do not use the Worktop lift unit as a lifting jack, e.g. for lifting things from the floor.
- Do not use the Worktop lift unit in a potentially explosive environment.
- When the operation is in a public location, particularly when children can enter the work area, the operator shall make satisfactory arrangements to prevent persons from entering the hazardous area when the lift is being operated, or it has been lowered from the parking position, e.g. by means of blocking the work area or by means of adding protection devices.
- Decals and markings must not be removed or made illegible.
- During inspections, service and repair work there shall be no load on the worktop or in the cabinets. The most common functions can be reached when the cover panels have been removed.
- Competent persons only must carry out installation, service and repair works.
- Only Granberg original spare parts shall be used when replacing any parts. Our warranty commitment can otherwise be invalidated.

5.2 Safety arrangements

The underside of the Worktop lift unit is provided with a security strip. If the security strip is pressed during lowering, the worktop lift unit shall stop immediately.

Check the security strip function often.



5.3 Load distribution and side forces

Note that the max. rated load means that the load is distributed over and inside the entire Worktop Lift. Point loads are not allowed.

It is absolutely forbidden for persons to stay on the worktop, to stand on extended drawers and chopping boards or to use the lift for lifting persons.

Basic loading requirements:

* **100 % of the rated load distributed over the entire cabinet volume.**

* **Horizontal forces are not allowed.**

Horizontal forces can appear, for example, when pressing onto the shelves or the load. It is difficult to estimate the size of the actual horizontal force, so utmost care must always be taken.

Further to the incorporated safety arrangements additional can safety actions may be required on or at the Worktop lift unit. Discuss suitable actions with your Granberg representative or with the health and safety inspection.

We recommend that a Risk assessment in accordance with the Machinery Directive shall be made for the actual working conditions. If the owner fits accessories, contact Granberg to get approval for the loading conditions.

5.4 Actions after use

The Worktop lift unit shall after use be left in its current position. Switch off the main switch and lock it in closed position, if unauthorized use can occur.

To prevent unauthorized use can it is also possible to furnish the control panel with a key switch, by means of which the control circuit is disconnected.

5.5 Alternative control devices

The operator shall have a clear view of the hazardous parts of the Worktop lift unit and its motions, but not directly within the work area, as there is a risk that objects may fall out from it. (Due to limited space it can be necessary to place the control devices is placed within the work area).



Control buttons UP / DOWN of aluminium, recessed.
The button unit is mounted recessed in workbench front, cabinet side etc.



Frame for several control devices
If the control devices have been brought together to a common control station it is important to clearly mark which buttons control resp. lifting device. This will decrease the risk for operating another lifting device than the desired.

In order to prevent unauthorized use the control position can be provided with a key switch.

See also section 5.1, "Safe use", regarding safe conditions and risks at handling the machine and the load!

5.6 Cleaning

In its use in a kitchen environment the mechanism can be exposed to dirt. As the worktop lift unit contains electrical components it is very important that cleaning is made according this instruction.

WARNING!

- * The Worktop lift unit must absolutely not be connected to the electric supply when cleaning is carried out.
- * The Worktop lift unit must absolutely not be rinsed with water! (not applicable for the sink).

Care instructions:

Remove the cover panels under the Worktop unit, in front of the mechanism. The Worktop lift unit is cleaned with lukewarm water and a non-scratching detergent containing soap or similar. Use a Wettex swab or similar. After cleaning the surfaces shall be dried to avoid lime deposits.

5.7 Maintenance

The Worktop lift unit is maintenance-free. Greasing and other actions are made during the manufacturing for the lifetime of the lift. From safety point of view however some components shall be inspected each year.

- * Inspections, service and repair work shall be made by competent persons.
 - * Remove the objects from the Worktop unit before maintenance and repair works are made.
1. Run the lift down and up all the way to resp. end position. Check that it runs freely without trapping risks and jarring sounds. Check that it stops and stays in the lower resp. upper positions.
 2. Lower the Worktop unit and lift the safety frame under Worktop unit to check that this operates properly. The Worktop unit shall stop immediately.
 3. Check that the cables are not chafed, squeezed or breaking.
 4. Check that the wall attachments are in proper order.
 5. If the Worktop is inclined adjustment can be made according to the installation instructions.

Accomplished inspections and repair works shall be specified in the service records in section 9.

6. Instructions for recycling

When the Worktop lift unit is reused make sure that safety trip panel is the right size.

When the Diagonal lift unit shall be re-used shall it must be cleaned, inspected and go through a full operation test before it is installed on the new site.

We recommend the machine to be sent to Granberg or to the Granberg distributor to get this done. The machine is manufactured from re-usable materials or from materials that can be recycled.

7. Decals

Two decals are included in the instruction manual envelope, and these must be placed in the kitchen.



Risk of crushing at the front of the countertop

If the countertop on the worktop lift and countertop to adjacent cabinets stand out in front of each cabinet frame, there is a risk of crushing.

Place the sign that warns of the risk of crushing on the short side of the countertop on the worktop lift.

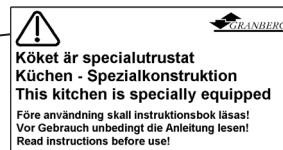

The decal that explains that the kitchen is specially equipped shall be placed close to the control the button.



The Max. load decal shall be placed at the push button box.

8. Warranty

In accordance with the warranty conditions Orgalime S 2000 the manufacturer will replace or repair all faults which depend on manufacturing or material faults and which appear within twenty-four (24) months from the delivery. For further details about the conditions, see Orgalime S 2000.

Note! Alternative warranty conditions may apply. See the Order Acknowledgement for actual conditions.

The warranty is only valid if inspections and maintenance is carried out in accordance with the instructions. This warranty does not cover the cost of normal maintenance, settings or scheduled adjustments as specified in the instructions. Also the labour costs for such actions are not covered by the warranty.

Damages caused by misuse or incorrect operation of the equipment means that the warranty would expire.

Before any warranty work is commenced by a customer Granberg must be contacted for analysis and approval. We do not accept to carry any warranty costs if the repair work has started without an agreement by us.

Do not return any parts that have been worn out during normal operation or accidentally damaged. Only return worn or damaged parts if it is considered that the fault is covered by our warranty conditions. In such cases, return the parts without delay, otherwise the right to replacement may be lost.

When returning parts always quote the details shown on the manufacturer's plate, i.e.

Type, manufacturing number, year
and describe the operating conditions for the machine.

Remember to quote name, address and telephone number for the appropriate contact person.

9. Service and Maintenance Records

Type and model: _____ Manufacturing No.: _____

Delivery date: _____

Service & maintenance Date: _____ Sign. _____ Remarks: _____ _____ _____	Service & maintenance Date: _____ Sign. _____ Remarks: _____ _____ _____	Service & maintenance Date: _____ Sign. _____ Remarks: _____ _____ _____
Service & maintenance Date: _____ Sign. _____ Remarks: _____ _____ _____	Service & maintenance Date: _____ Sign. _____ Remarks: _____ _____ _____	Service & maintenance Date: _____ Sign. _____ Remarks: _____ _____ _____

10. Fault finding

The Worktop lift unit is designed and tested to achieve optimum operation reliability and long life, provided that the operation, maintenance and inspections are carried out in accordance with the prescribed instructions. If in spite of this a fault appears you can get guidance about what to do according to the fault finding list below.

Remove the load from the cabinet before fault finding and repair work is carried out.
Fault finding, service and repair work shall be made by competent persons only.

If any problem remains after you have taken actions in accordance with the list below you must contact a competent technician or your supplier.

Symptom	Action
The worktop lift unit does not move when pushing the button.	Check that the mains plug is connected.
	Check that the wires are properly fastened in the control device.
	Try to reset the system by pushing the button for down in 5 sec. The reset has succeeded when you hear a "click" sound. Try to run the worktop lift unit down and up all the way to respectively end position.
The worktop lift unit does not move when pushing the button and it clicks three times from the control box.	The worktop lift is not possible to run if the connection to the security strip is broken. Check that the security strip is connected and that there are no damages. Check the connections between the security strips if the worktop lift has several security strips.
The lift is not in line, the motors are in different positions.	Run the worktop lift down until it stops. Press down again and wait until the motor legs are in line. Now you have synchronized the motor legs.

When repair work has been carried out on the Worktop lift unit a complete functional test with full load shall be made, before it is taken into use. (See section 4.16).

11. Spare parts list

If any component does not work or has broken, contact your supplier. Only Granberg original spare parts must be used when replacing any parts. Our warranty commitment may otherwise be invalidated.

Return of spare parts:

Contact Granberg prior to any return of parts.

Do not return any parts that have been worn out during normal operation or accidentally damaged. Only return worn or damaged parts if it is considered that the fault is covered by our warranty conditions. In such cases, return the parts without delay, otherwise the right to replacement may be lost.

When ordering spare parts always quote the manufacturing number and type.

Pos: Description:

- 1 Motor
- 2 Control box
- 3 Key for safety lock
- 4 Security strip
- 5 Recessed push button box, aluminium

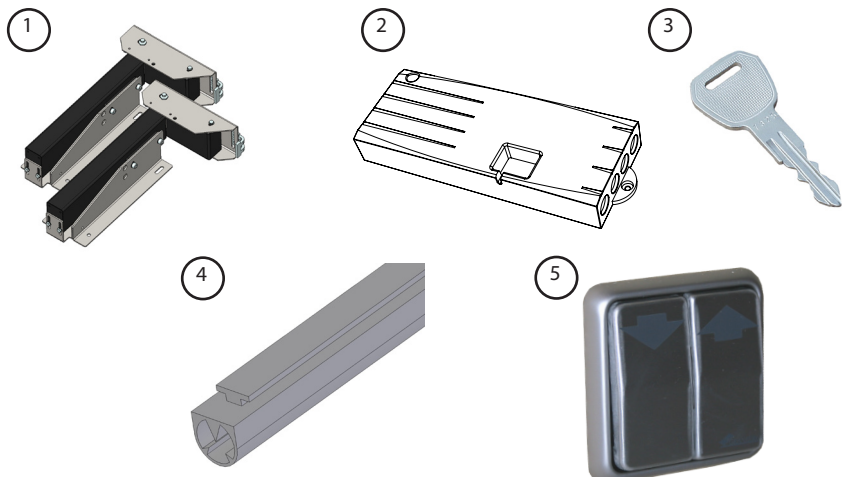

12. Electric system / Electric diagram

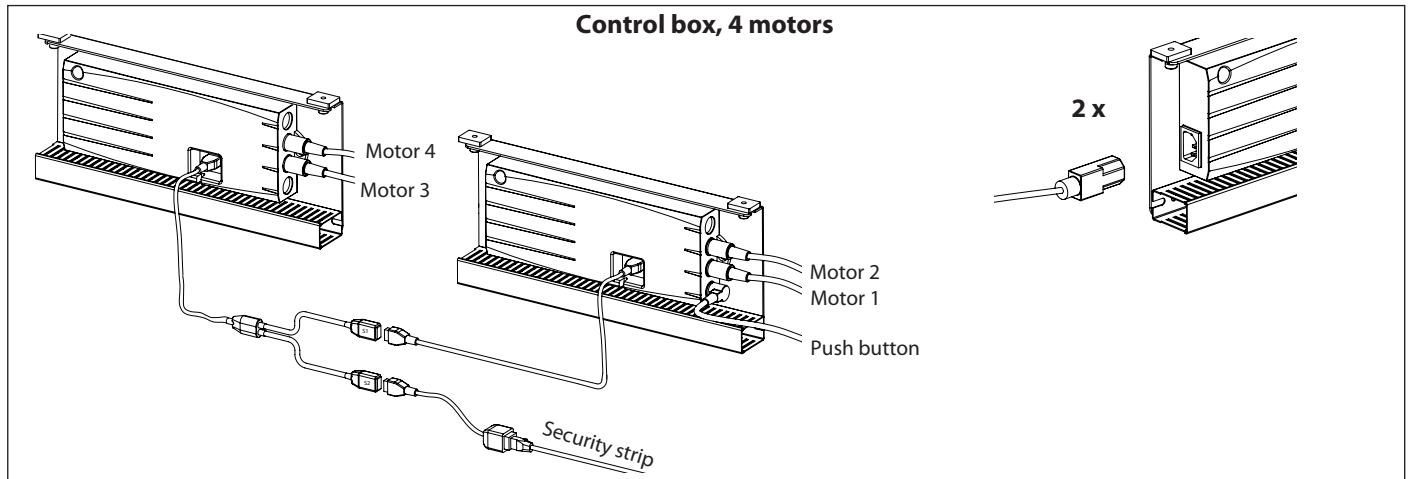
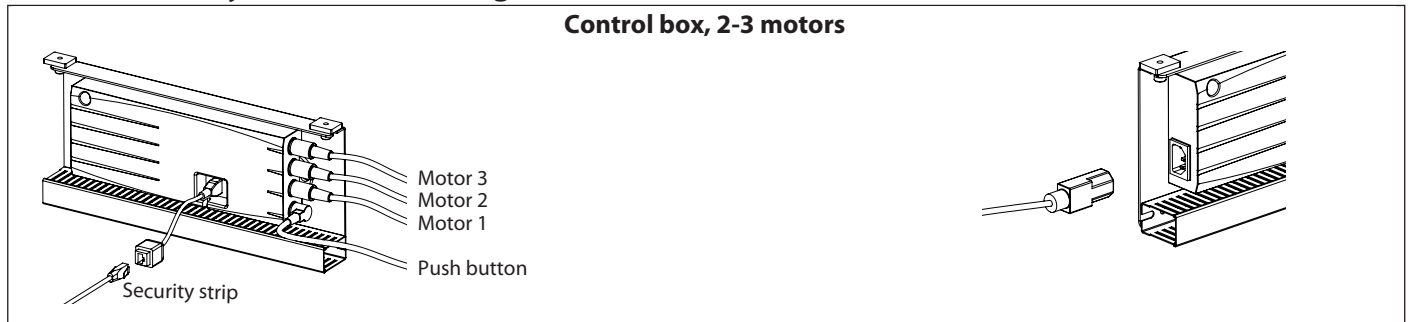

13. CE-Declaration of conformity

(According Machinery Directive 2006/42/EG, Annexe 2A)

Manufacturer: Granberg Interior AB
 Box 6112,
 SE-600 06 NORRKÖPING, Sweden

Tel. +46-11-19 77 50



declares under sole responsibility that the product:

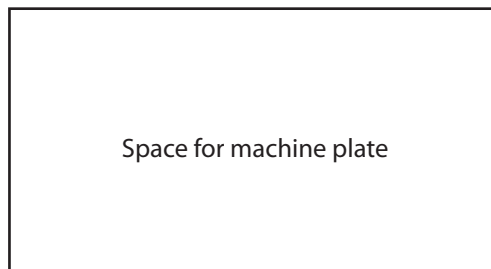

to which this declaration relates, is in manufactured in conformity with the following harmonised documents, following the provisions of Machinery Directive 2006/42/EG, the Low Voltage Directive 2014/35/EU and the EMC Directive 2014/30/EU.

It also conforms to the following harmonised standards:

EN 60204-1:2006	Safety of Machinery - Electrical Equipment of Machines -General Requirements
EN ISO 13857:2008	Safety distances to prevent hazard zones being reached by upper and lower limbs
EN 349:1993+A1:2008	Safety of machinery. Minimum gaps to avoid crushing of parts of the human body

The undersigned is authorized to assemble the technical documentation.
 Norrköping, 2017-06-19

Tobias Granberg, VD
 Managing Director



GRANBERG

Granberg Interior AB
Box 6112 600 06, Norrköping, Sweden
Tel: +46(0)11-19 77 50
E-mail: info@granberg.se
Internet: www.granberg.se