

MOLNIGT

GB



Design and Quality
IKEA of Sweden



Please refer to the last page of this manual for the full list of IKEA appointed Authorized Service Centre and relative national phone numbers.

ENGLISH

4

Contents

Safety information	4	What to do if ...	10
Product description	7	Technical data	11
Control panel	8	Environmental concerns	12
Cleaning and maintenance	8	IKEA GUARANTEE	13

Safety Information

Before first use

Your safety and that of others is paramount.

Remove cardboard protection pieces, protective film and adhesive labels from accessories.

Check the appliance for any transport damage.

To avoid any damage do not place any weights on the appliance. Do not expose the appliance to atmospheric agents.

This manual and the appliance itself provide important safety warnings, to be read and observed at all times.

 This is the attention symbol, pertaining to safety, which alerts users to potential risks to themselves and others.

All safety warnings are preceded by the attention symbol and the following terms:

 **DANGER:** indicates a hazardous situation which, if not avoided, will cause serious injury.

 **WARNING:** Indicates a hazardous situation which, if not avoided, could cause serious injury.

All safety warnings give specific details of the potential danger/warning present and indicate how to reduce risk of injury, damage and electric shock resulting from improper use of the appliance. Carefully observe the following instructions.

Precautions and general recommendations

- The electrical installation and the electrical connection must be carried out by a qualified technician according to the manufacturer's instructions and in compliance with the local safety

regulations. Do not repair or replace any part of the appliance unless specifically stated in the user manual.

- The appliance must be disconnected from the power supply before carrying out any installation work.
- Earthing of the appliance is compulsory. (required only for class I).
- The power cable must be long enough for connecting the appliance, once fitted in its housing, to the power supply socket.
- Do not pull the power supply cable in order to unplug the appliance.
- The electrical components must not be accessible to the user after installation.
- Do not touch the appliance with any wet part of the body and do not operate it when barefoot.
- The appliance is not intended for use by persons (including children) with any physical, sensory or mental impairment, or without experience and knowledge of the appliance, unless supervised or previously instructed in its use by those responsible for their safety.
- Do not repair or replace any part of the appliance unless specifically indicated in the manual. All other maintenance services must be carried out by a specialised technician.
- Children must be supervised to ensure they do not play with the appliance.
- When drilling through the wall pay attention not to damage electric connections and/or pipes.
- Air vents must always discharge to the outside.

- The manufacturer rejects all responsibilities for any damage caused by improper use or wrong settings.
- Appropriate maintenance and cleaning ensure the good working order and the best performance of the appliance. Regularly clean all stubborn surface dirt to avoid grease build up. Remove and clean or change the filter regularly.
- Never flame cook food (flambé) under the appliance. Using free flames might cause fire.
- Failure to observe the instructions for cleaning the hood and replacing the filters may result in a fire.
- Exhaust air must not be vented through a flue used for removal of fumes produced by gas combustion appliances or other combustible materials, but must have a separate outlet. All national regulations governing extraction of fumes must be observed.
- There shall be adequate ventilation if the hood is being used at the same time as other appliances using gas or other combustible materials. The negative pressure of the room must not exceed 4 Pa (4x 10⁻⁵ bars). For this reason ensure that the room is well ventilated.
- Do not leave frying pans unattended when frying, as the frying oil may catch fire.
- Before touching the light bulbs, ensure that they are cold.
- Do not use or leave the hood without the light bulb correctly fitted, as this may cause electric shock.
- The hood is not a work surface, therefore do not place any objects on top of it or overload it.
- During all installation and maintenance operations wear appropriate working gloves.
- This appliance is not suitable for outdoor use.

 **WARNING:** when the hob is in use, accessible parts of the hood may become hot.

Installation and connection

After unpacking the appliance, check for any transport damage. In the event of problems, contact the Authorized Service Centre. To prevent any damage, only remove the appliance from its polystyrene foam packaging at the time of installation.

Preparing for installation

 **WARNING:** this is a heavy product; the hood should only be lifted and installed by two or more people.

The minimum distance between the hob and the bottom part of the hood must not be less than 65 cm for burning gas or other fuels and 50cm for electric cookers.

Before installation also check the minimum distances stated in the manual of the cooker. If the installation instructions for the cooker specify a greater distance between cooker and hood, this distance must be observed.

Electrical connection

Make sure the power voltage specified on the appliance rating plate is the same as the mains voltage.

This information can be found on the inside of the hood, under the grease filter. Power cable replacement (type H05 VV-F) must be carried out by a qualified electrician. Contact an authorized service centre.

If the hood is fitted with an electric plug, connect the plug to a socket complying with current regulations, located in an accessible place.

If no plug is fitted (direct wiring to the mains), or if the socket is not located in an accessible place, a qualified electrician should install a standardised double pole power switch that will enable complete isolation from the mains in case of category III overvoltage conditions, in accordance with wiring rules.

Use

The hood has been designed to be installed and used either as a “Exhausted model”, or as a “Recirculation model”.

Exhausted model (see symbol  in installation booklet)

Cooking steam is sucked and channelled outside the house through a discharge duct (not supplied), fitted to the hood steam outlet.

Ensure that the discharge duct is correctly fitted to the air outlet, unit using an appropriate connection system.

Important: If already installed, remove the charcoal filter/s.

Recirculation model (see symbol  in installation booklet)

The air is filtered through one or more the charcoal filters, and then resent into room.

Important: Ensure appropriate air circulation around the hood.

Important: If the hood is supplied without charcoal filters, these must be fitted before the hood can be used. Filters are available in shops.

The hood should be installed away from particularly dirty areas, windows, doors and heat sources.

The accessories for wall fixing are not included because walls made of different materials require different types of fixing accessories. Use fixing systems suitable for the walls of your home and the weight of the appliance. For more details, contact a specialized dealer.

Keep this booklet for future consultation.

Product description

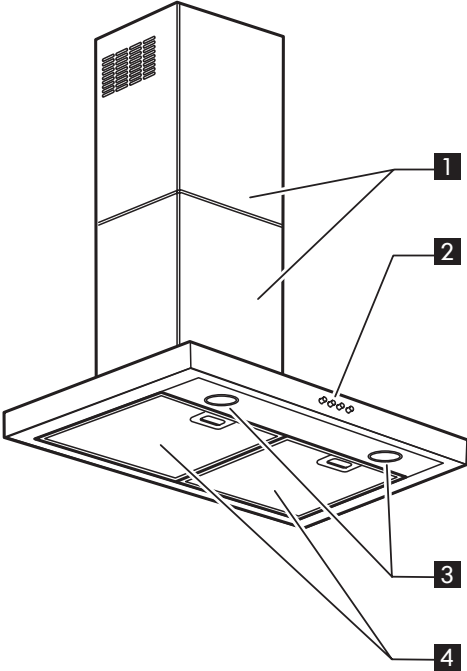

- 1** Chimney.
- 2** Control Panel.
- 3** Light.
- 4** Grease filter.

Control panel

- A** Light ON/OFF button.
- B** Motor ON/OFF button / Extraction power 1 selection button.
- C** Extraction power 2 selection button.
- D** Extraction power 3 selection button.

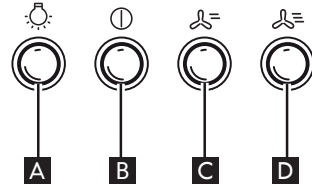

Cleaning and maintenance

WARNING: - Never use steam cleaning equipment.

- Disconnect the appliance from the power supply.

IMPORTANT: do not use corrosive or abrasive detergents. If any of these products accidentally comes into contact with the appliance, clean immediately with a damp cloth.

- Clean the surfaces with a damp cloth. If it is very dirty, add a few drops of washing up detergent to the water. Finish off with a dry cloth.

IMPORTANT: do not use abrasive sponges or metallic scrapers or scourers. Over time, these can ruin the surface.

- Use detergents specifically designed for cleaning the appliance and follow the manufacturer instructions.

IMPORTANT: clean the filters at least monthly to remove any oil or grease residuals.

To clean the grease filter

The metal grease filter has an unlimited life and must be washed once a month by hand or dishwasher at low temperature and with a short cycle. With cleaning in a dishwasher the grease filter may become dull; this does not effect its filtering capacity.

Grease filter maintenance:

1. Disconnect the hood from the electric power supply.
2. Remove the grease filters: pull the spring release handle downwards, then remove the filter.
3. After cleaning the grease filter, remount in reverse order ensuring the entire extraction surface is covered.

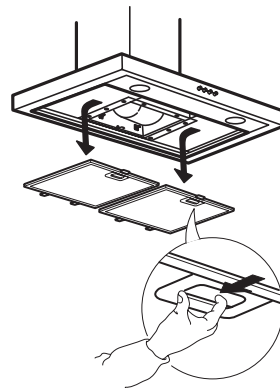

Charcoal filter maintenance (if the hood is installed in recirculation mode)

1. Unplug the appliance or disconnect the power supply.
2. Remove the grease filter
3. Remove charcoal filter holder
4. Remove/add charcoal filter
5. Fix metal wire to keep the charcoal filter in the correct position
6. Hook the carbon filter firstly to the metal tab at the back on the hood.
7. Fix it at the front with the two knobs.
8. Refit the grease filter.

Unlike traditional charcoal filters, this charcoal filter can be washed and reactivated.

With normal hood use, the filter should be cleaned once a month. The best way to clean the filter is in a dishwasher at the highest temperature possible, using a normal dishwasher detergent. To avoid particles of food or dirt settling on the filter during washing and giving rise to unpleasant smells, it is advisable to wash the filter on its own. After washing, dry the filter in the oven at 100°C for 10 minutes to reactivate it. The filter will retain its odour-absorbing capacity for three years, after which it will have to be replaced.

Lamp maintenance

Disconnect the hood from the electricity.

Warning

Prior to touching the light bulbs ensure they are cooled down.

1. Use a small screwdriver or other suitable tool to prise off the cover.
2. Snap-fit the cover back on.
3. Use only max 12V-10W- G4 halogen bulbs.

IMPORTANT: make sure you don't touch the lamp with your bare hands.

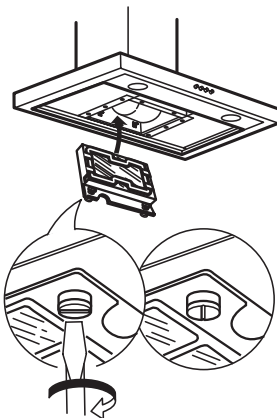
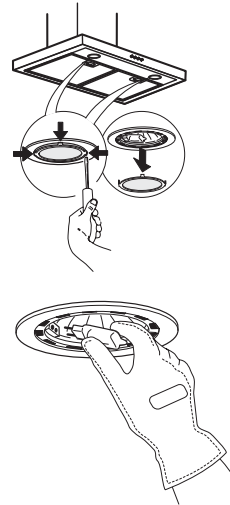

What to do if ...

Problem	Possible cause	Solution
The appliance does not work	There is no mains electrical power	Check for the presence of mains electrical power. Turn off the appliance and restart it to see if the faults persists.
	The appliance is not connected to the electrical supply	Check if the appliance is connected to the electrical supply. Turn off the appliance and restart it to see if the faults persists.
The hood's suction level is not enough	The suction speed is too low	Check the suction speed and adjust as necessary.
	The metal filters are dirty	Check that the filters are clean. If not, clean the filters in the dishwasher.
	The air vents are obstructed	Check the air vents for any obstructions and remove as necessary.
The light does not work	The light bulb is broken	Check the light bulb and replace it if necessary.
	The light bulb is not correctly fitted	Check that the light bulb has been correctly fitted. If not, fit the light bulb in right way.

Before contacting the Authorized Service Centre:

Switch the appliance on again to see if the problem has disappeared. If not, switch it off again and repeat the operation after an hour.

If your appliance still does not work properly after carrying out the checks listed in the troubleshooting guide and switching the appliance on again, contact the Authorized Service Centre, clearly explaining the problem and specifying:

- the type of fault;

- the model;
- the type and serial number of the appliance (given on the rating plate);
- the Service number (the number after the word SERVICE on the rating plate inside the appliance).

SERVICE 0000 000 00000



Technical data

Type of product		Wall mounted hood	
Dimensions	Width	mm	600
	Depth	mm	450
	Height min	mm	600
	Height max	mm	1113
Total power		W	270
Lamps info	Type		Halogen
	Number & Power	W	2x10W
	Socket		Spotlight
Installation minimum height - gas hob		mm	650
Installation minimum height - elec hob		mm	500
Product Weight		Kg	11
Additional Product Information compliant to commission regulation (EU) No 66/2014			
Model identifier			MOLNIGT 20304595 MOLNIGT 80304597 MOLNIGT 00304596 MOLNIGT 60304598 MOLNIGT 00304600 MOLNIGT 40304599
Annual Energy Consumption		kWh/a	67,3
Time increase factor			1
Fluid Dynamic Efficiency		%	28
Energy Efficiency Index			63,6
Measured air flow rate at best efficiency point		m ³ /h	336
Measured air pressure at best efficiency point		Pa	434
Maximum air flow		m ³ /h	603
Measured electric power input at best efficiency point		W	144,5
Nominal power of the lighting system		W	20
Average illumination of the lighting system on the cooking surface		lux	100
Power consumption in standby mode		W	0
Power consumption off mode		W	0
A-waighted Sound Power Emission at maximum speed		dB(A)	69

The technical information is situated in the rating plate on the internal side of the appliance.

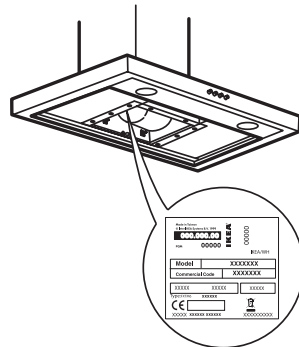

Environmental concerns

Disposal of packing

The packing material is 100% recyclable and is marked with the recycle symbol . The various parts of the packing must therefore be disposed of responsibly and in full compliance with local authority regulations governing waste disposal.

Scrapping the product

- This appliance is marked in compliance with European Directive 2012/19/EU, Waste Electrical and Electronic Equipment (WEEE).
- By ensuring this product is disposed of correctly, you will help prevent potential negative consequences for the environment and human health, which could otherwise be caused by inappropriate waste handling of this product.



The symbol  on the product or on the accompanying documentation indicates that it should not be treated as domestic waste but must be taken to an appropriate collection centre for the recycling of electrical and electronic equipment.

Scrapping of household appliances

- This appliance is manufactured with recyclable or reusable materials. Dispose of it in accordance with local waste disposal regulations. Before scrapping, cut off the power supply cable.
- For further information on the treatment, recovery and recycling of household electrical appliances, contact your competent local authority, the collection service for household waste or the store where you purchased the appliance.

Energy saving tips

- Switch ON the hood at minimum speed when you start cooking and kept it running for few minutes after cooking is finished.
- Increase the speed only in case of large amount of smoke and vapour and use boost speed(s) only in extreme situations.
- Replace the charcoal filter(s) when necessary to maintain a good odour reduction efficiency.
- Clean the grease filter(s) when necessary to maintain a good grease filter efficiency.
- Use the maximum diameter of the ducting system indicated in this manual to optimize efficiency and minimize noise.

Declaration of conformity



- This appliance has been designed, manufactured and marketed in compliance with:
 - safety objectives of the “Low Voltage” Directive 2006/95/EC (which replaces 73/23/EEC and subsequent amendments);
 - the eco design requirements of european regulations n. 65/2014, and n. 66/2014 in conformity to the european standard en 61591-1;
 - the protection requirements of Directive “EMC” 2004/108/EC.

Electrical safety of the appliance can only be guaranteed if it is correctly connected to an approved earthing system.

IKEA GUARANTEE

How long is the IKEA guarantee valid?

This guarantee is valid for five (5) years from the original date of purchase of your appliance at IKEA, unless the appliance is named LAGAN in which case two (2) years of guarantee apply. The original sales receipt, is required as proof of purchase. If service work is carried out under guarantee, this will not extend the guarantee period for the appliance.

Which appliances are not covered by the IKEA five (5) years guarantee?

The range of appliances named LAGAN and all appliances purchased in IKEA before 1st of August 2007.

Who will execute the service?

IKEA service provider will provide the service through its own service operations or authorized service partner network.

What does this guarantee cover?

The guarantee covers faults of the appliance, which have been caused by faulty construction or material faults from the date of purchase from IKEA. This guarantee applies to domestic use only. The exceptions are specified under the headline "What is not covered under this guarantee?" Within the guarantee period, the costs to remedy the fault e.g. repairs, parts, labour and travel will be covered, provided that the appliance is accessible for repair without special expenditure. On these conditions the EU guidelines (Nr. 99/44/EG) and the respective local regulations are applicable. Replaced parts become the property of IKEA.

What will IKEA do to correct the problem?

IKEA appointed service provider will examine the product and decide, at its sole discretion, if it is covered under this guarantee. If considered covered, IKEA Service Provider or its authorized service partner through its own service operations, will then, at its sole discretion, either repair the defective product or replace it with the same or a comparable product.

What is not covered under this guarantee?

- Normal wear and tear.
- Deliberate or negligent damage, damage caused by failure to observe operating instructions, incorrect installation or by connection to the wrong voltage, damage caused by chemical or electrochemical reaction, rust, corrosion or water damage including but not limited to damage caused by excessive lime in the water supply, damage caused by abnormal environmental conditions.
- Consumable parts including batteries and lamps.
- Non-functional and decorative parts which do not affect normal use of the appliance, including any scratches and possible color differences.
- Accidental damage caused by foreign objects or substances and cleaning or unblocking of filters, drainage systems or soap drawers.
- Damage to the following parts: ceramic glass, accessories, crockery and cutlery baskets, feed and drainage pipes, seals, lamps and lamp covers, screens, knobs, casings and parts of casings. Unless such damages can be proved to have been caused by production faults.
- Cases where no fault could be found during a technician's visit.
- Repairs not carried out by our appointed service providers and/or an authorized service contractual partner or where non-original parts have been used.
- Repairs caused by installation which is faulty or not according to specification.
- The use of the appliance in a non-domestic environment i.e. professional use.
- Transportation damages. If a customer transports the product to his home or another address, IKEA is not liable for any damage that may occur during transport. However, if IKEA delivers the product to the customer's delivery address, then damage to the product that occurs during this delivery will be covered by IKEA.

- Cost for carrying out the initial installation of the IKEA appliance.
However, if an IKEA appointed Service Provider or its authorized service partner repairs or replaces the appliance under the terms of this guarantee, the appointed Service Provider or its authorized service partner will reinstall the repaired appliance or install the replacement, if necessary.
- This does not apply within Ireland, customer should contact the local IKEA dedicated after sales line or the appointed Service Provider for further information.

(just for GB)

These restrictions do not apply to fault-free work carried out by a qualified specialist using our original parts in order to adapt the appliance to the technical safety specifications of another EU country.

How country law applies

The IKEA guarantee gives you specific legal rights, which cover or exceed all the local legal demands.

However these conditions do not limit in any way consumer rights described in the local legislation.

Area of validity

For appliances which are purchased in one EU country and taken to another EU country, the services will be provided in the framework of the guarantee conditions normal in the new country.

An obligation to carry out services in the framework of the guarantee exists only if the appliance complies and is installed in accordance with:

- the technical specifications of the country in which the guarantee claim is made;
- the Assembly Instructions and User Manual Safety Information.

The dedicated AFTER SALES for IKEA appliances

Please don't hesitate to contact IKEA appointed Authorized Service Centre to:

- make a service request under this guarantee;

- ask for clarifications on installation of the IKEA appliance in the dedicated IKEA kitchen furniture;
- ask for clarification on functions of IKEA appliances.

To ensure that we provide you with the best assistance, please read carefully the Assembly Instructions and/or the User Manual before contacting us.

How to reach us if you need our service



Please refer to the last page of this manual for the full list of IKEA appointed Authorized Service Centre and relative national phone numbers.

- i** In order to provide you a quicker service, we recommend to use the specific phone numbers listed on this manual. Always refer to the numbers listed in the booklet of the specific appliance you need an assistance for. Please also always refer to the IKEA article number (8 digit code) and 12 digit service number placed on the rating plate of your appliance.

- i** **SAVE THE SALES RECEIPT!**
It is your proof of purchase and required for the guarantee to apply. The sales receipt also reports the IKEA name and article number (8 digit code) for each of the appliances you have purchased.

Do you need extra help?

For any additional questions not related to After Sales of your appliances please contact your nearest IKEA store call centre. We recommend you read the appliance documentation carefully before contacting us.

**BELGIË - BELGIQUE - BELGIEN**

Telefoon/Numéro de téléphone/Telefon-Nummer:	026200311	
Tarief/Tarif/Tarif:	Lokaal tarief/Prix d'un appel local/Ortstarif	
Openingstijd:	Maandag - Vrijdag	8.00 - 20.00
Heures d'ouverture:	Lundi - Vendredi	8.00 - 20.00
Öffnungszeiten:	Montag - Freitag	8.00 - 20.00

БЪЛГАРИЯ

Телефонен номер:	02 4003536	
Тарифа:	Локална тарифа	
Работно време:	понеделник - петък	8.00 - 20.00

ČESKÁ REPUBLIKA

Telefonní číslo:	225376400	
Sazba:	Místní sazba	
Pracovní doba:	Pondělí - Pátek	8.00 - 20.00

DANMARK

Telefonnummer:	70150909	
Takst:	Lokal takst	
Åbningstid:	Mandag - fredag	9.00 - 21.00
	Lørdag	9.00 - 18.00
	(Åbent udvalgte søndage, se IKEA.dk)	

DEUTSCHLAND

Telefon-Nummer:	06929993602	
Tarif:	Ortstarif	
Öffnungszeiten:	Montag - Freitag	8.00 - 20.00

ΕΛΛΑΔΑ

Τηλεφωνικός αριθμός:	2109696497	
Χρέωση:	Τοπική χρέωση	
Ώρες λειτουργίας:	Δευτέρα - Παρασκευή	8.00 - 20.00

ESPAÑA

Teléfono:	913754126	
Tarifa:	Tarifa local	
Horario:	Lunes - Viernes	8.00 - 20.00
	(España Continental)	

FRANCE

Numéro de téléphone:	0170480513	
Tarif:	Prix d'un appel local	
Heures d'ouverture:	Lundi - Vendredi	9.00 - 21.00

HRVATSKA

Broj telefona:	0800 3636	
Tarifa:	Lokalna tarifa	
Radno vrijeme:	Ponedjeljak - Petak	8.00 - 20.00

ÍSLAND

Símanúmer:	5852409	
Kostnaður við símtal:	Almennt mínútuverð	
Opnunartími:	Mánudaga - Föstudaga	9.00 - 17.00

ITALIA

Telefono:	0238591334	
Tariffa:	Tariffa locale	
Orari d'apertura:	Lunedì - Venerdì	8.00 - 20.00

LIETUVIŲ

Telefono numeris:	(0) 520 511 35	
Skambūčio kaina:	Vietos mokestis	
Darbo laikas:	Nuo pirmadienio iki penktadienio	8.00 - 20.00

MAGYARORSZÁG

Telefon szám:	(06-1)-3285308	
Tarifa:	Helyi tarifa	
Nyitvatartási idő:	Hétfőtől Péntekig	8.00 - 20.00

NEDERLAND

Telefoon:	09002354532 en/of 0900 BEL IKEA	
Tarief:	15 cent/min., starttarief 4.54 cent en gebruikelijke belkosten	
Openingstijd:	Maandag t/m - Vrijdag	8.00 - 20.00
	Zaterdag	9.00 - 20.00
	Zondag	gesloten

NORGE

Telefon nummer:	23500112	
Takst:	Lokal takst	
Åpningstider:	Mandag - fredag	8.00 - 20.00

ÖSTERREICH

Telefon-Nummer:	013602771461	
Tarif:	Ortstarif	
Öffnungszeiten:	Montag - Freitag	8.00 - 20.00

POLSKA

Numer telefonu:	225844203	
Stawka:	Koszt połączenia według taryfy operatora	
Godziny otwarcia:	Poniedziałek - Piątek	8.00-20.00

PORTUGAL

Telefone:	213164011	
Tarifa:	Tarifa local	
Horário:	Segunda - Sexta	9.00 - 21.00

REPUBLIC OF IRELAND

Phone number:	016590276	
Rate:	Local rate	
Opening hours:	Monday - Friday	8.00 - 20.00

ROMÂNIA

Număr de telefon:	021 2044888	
Tarif:	Tarif local	
Orar:	Luni - Vineri	8.00 - 20.00

РОССИЯ

Телефонный номер:	84957059426	
Стоимость звонка:	Местная стоимость звонка	
Время работы:	Понедельник - Пятница	9.00 - 21.00
	(Московское время)	

SCHWEIZ - SUISSE - SVIZZERA

Telefon-Nummer/Numéro de téléphone/Telefono:	0225675345	
Tarif/Tarif/Tariffa:	Ortstarif/Prix d'un appel local/Tariffa locale	
Öffnungszeiten:	Montag - Freitag	8.00 - 20.00
Heures d'ouverture:	Lundi - Vendredi	8.00 - 20.00
Orario d'apertura:	Lunedì - Venerdì	8.00 - 20.00

SLOVENSKO

Telefónne číslo:	(02) 50102658	
Cena za hovori:	Cena za miestny hovor	
Pracovná doba:	Pondelok až piatok	8.00 - 20.00

SRBIJA

<http://www.ikea.com>

SUOMI

Puhelinnumero:	0981710374	
Hinta:	Yksikköhinta	
Aukioloaika:	Maanantaista perjantaihin 8.00 - 20.00	

SVERIGE

Telefon nummer:	0775-700 500	
Taxa:	Lokal samtal	
Öppet tider:	Måndag - Fredag	8.30 - 20.00
	Lördag - Söndag	9.30 - 18.00

UNITED KINGDOM

Phone number:	02076601517	
Rate:	Local rate	
Opening hours:	Monday - Friday	9.00 - 21.00

